

Torque Limiters



Features

- Prevent machine damage
- Eliminates costly down time
- No expensive electronics
- Simple installation
- No manual resetting required
- For use with CHALLENGE sprockets, gears, pulleys, couplings etc

Torque Limiters

Challenge Torque Limiter

The Challenge Torque limiter is a mechanical protective device that limits the transmitted torque in a drive system by slipping when the torque demand exceeds a preset value. This excessive torque is normally a result of shock loads, overloads, or machine jams. The torque limiter automatically re-engages when the overload is removed. No manual re-setting is required. Challenge Torque Limiters prevent machine damage, thus eliminating costly downtime.

Challenge Torque Limiters utilize spring loaded friction discs for their operation and slip torque is preset by adjustment of the spring force using the adjustment nut or bolts.

Challenge Torque Limiters can be used with platewheel sprockets, gears, pulleys, or flange plates as the centre member. This centre member is clamped between two friction discs.

Because the Challenge Torque Limiter ratings are realistic and consistent with optimum spring loads, they permit longer slip time, maintain re-engagement at preset torque and provide long lasting machine protection. This is an important advantage over the shear-pin mechanism which only serves as a one-shot remedy.



Sizes 50-1 and 50-2

- Single Nut Adjustment
- Lock Washer to prevent the nut from loosening



Sizes 65-1 and 65-2 Sizes 89-1 and 89-2

- Single Nut Adjustment
- Lock Washer to prevent the nut from loosening



Sizes 127-1 and 127-2 Sizes 178-1 and 178-2

- Three Bolts Adjustment
- Torque preset by the three bolts (an adjustment nut to fix a pilot plate in place)

Designation

89 - 1

Number of spring discs
Size

Torque Limiters

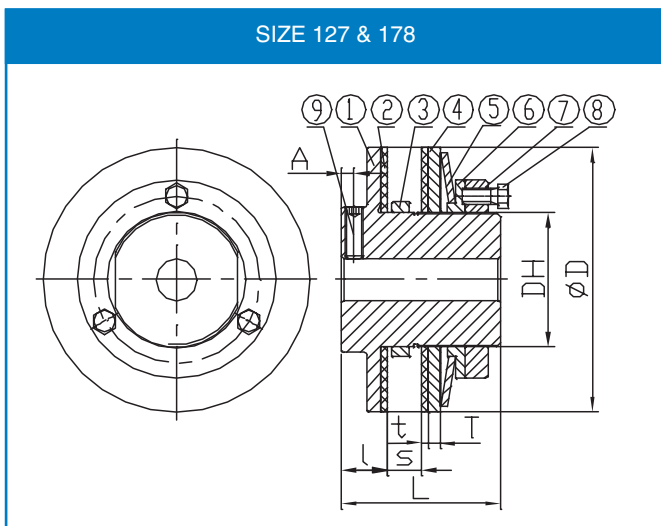
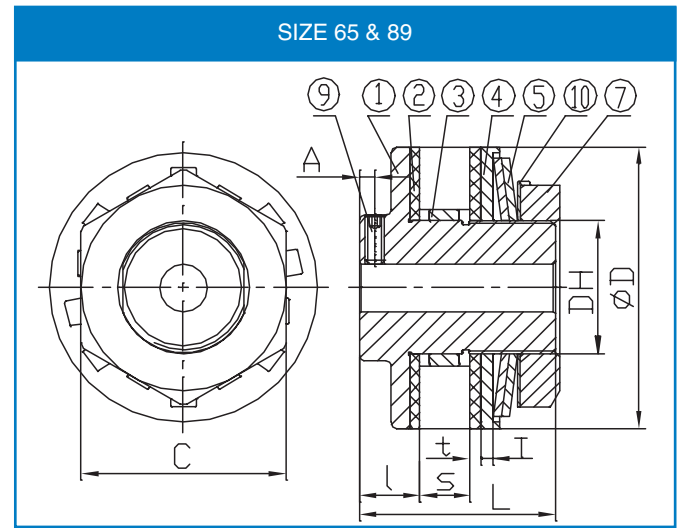
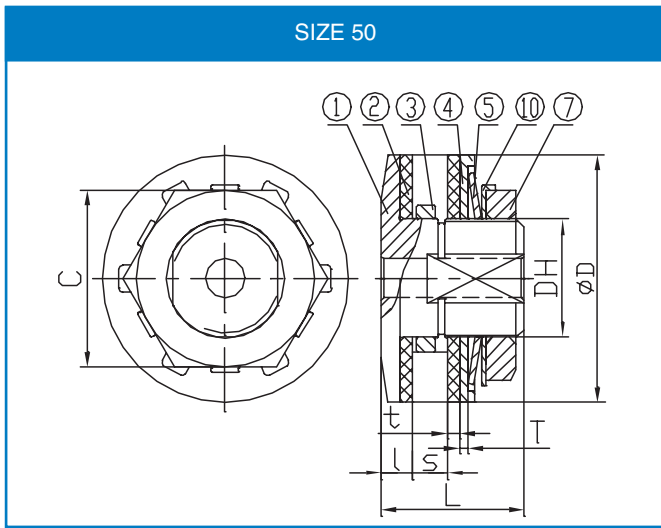

- Description of parts**
- ① Hub
 - ② Friction Disc
 - ③ Bush
 - ④ Pressure Plate
 - ⑤ Disc Spring
 - ⑥ Pilot Plate
 - ⑦ Adjustment Nut
 - ⑧ Adjustment Bolt
 - ⑨ Set Screw
 - ⑩ Lock Washer

Dimensions and Capacity for Sizes 50 to 178

Size	Torque Range kg.m	Plain Bore	Max. Bore	Bush Length	O.D. of Bush	Bore for Centre Member	D	DH	L	I	T	t	S (Max)	A	C	Adjust. Nut	Adjust. Bolt	Set Screw	Weight kg
50-1	0.3 ~ 1.0	8	14	3.8	30 -0.020	30 +0.033	50	24	29	6.5	1.6	2.5	7	-	36	M24	-	-	0.248
50-2	0.7 ~ 2.0			6.0	30 -0.041	30 +0										P1.0	-	-	0.256
65-1	0.7 ~ 2.8	10	22	6.0	41 -0.025	41 +0.039	65	35	48	16.0	4.0	3.2	9	4.0	50	M35	-	M5	0.721
65-2	1.4 ~ 5.5			8.0	41 -0.050	41 +0										P1.5	-	M5	0.739
89-1	2.0 ~ 7.6	17	25	6.0	49 -0.025	49 +0.039	89	42	62	19.0	4.0	3.2	16	5.0	65	M42	-	M6	2.417
89-2	3.5 ~ 15.2			8.0												49 -0.050	49 +0	P1.5	-
127-1	4.8 ~ 21.4	20	42	6.0	74 -0.030	74 +0.046	127	65	76	22.0	6.0	3.2	16	6.0	-	M65	M8	M8	3.692
127-2	9.0 ~ 42.9			8.0												74 -0.060	74 +0	P1.5	P1.0
				9.5															
				14.5															
178-1	11.8 ~ 58.1	30	64	8.0	105 -0.036	105 +0.054	178	95	98	24.0	7.0	3.2	29	6.5	-	M95	M10	M10	9.033
178-2	22.8 ~ 111			9.5												105 -0.071	105 +0	P1.5	P1.25
				14.5															
				17.0															
				22.0															

1 kg.m = 9.81 Nm

Torque Limiters

SELECTION PROCEDURE

1. Determine the required slip torque required for the machine. If the slip torque is not known then set the torque limiter to 1.5 ~ 2 times the torque that the motor produces on the shaft where the torque limiter is to be mounted.
2. From the Torque Range column, select a torque limiter that has sufficient torque. Also ensure that the chosen size can accommodate the required bore.
3. Based on the thickness of the centre member to be inserted between the friction discs, determine the required bush length. Always choose a bush, which will not exceed the width of the centre member. The maximum width of the centre member that can be accommodated is shown as "S max." in the dimension table.

Note: All Challenge Torque limiters are stocked with the longest bush length.

Therefore it may be necessary to machine the bush to suit the required centre member

Bore Sizes, Minimum Recommended number of Sprocket Teeth and Bush Lengths

Size	Bore of Centre Member (mm)	Sprocket Pitch and Number of Teeth													
		9.525 – (06B)		12.7 – (08B)		15.875 – (10B)		19.05 – (12B)		25.4 – (16B)		31.75 – (20B)		38.1 – (24B)	
		Sprocket Min Teeth	Bush Length (mm)	Sprocket Min Teeth	Bush Length (mm)	Sprocket Min Teeth	Bush Length (mm)	Sprocket Min Teeth	Bush Length (mm)	Sprocket Min Teeth	Bush Length (mm)	Sprocket Min Teeth	Bush Length (mm)	Sprocket Min Teeth	Bush Length (mm)
50	30	20	3.8	16	6										
65	41			20	6	17	8								
89	49			26	6	21	8	18	9.5	15	14.5				
127	74			35	6	29	8	25	9.5	19	14.5				
178	105					39	8	33	9.5	26	14.5	21	17	18	22

SETTING THE TORQUE

Setting the torque on the limiter is achieved by tightening or loosening the adjustment nut and/or the adjustment bolts. An adjustment nut is provided for torque adjustment on the size 50 through to size 89. On the sizes 127 and 178, the adjustment is accomplished by adjusting the provided bolts.

If the torque limiter slips under normal loading conditions, tighten the nut (for size 50 ~ size 89) or the bolts (for size 127 ~ size 178) gradually until the torque limiter stops slipping.

Always tighten (or loosen) the bolts or nut evenly. Try this adjustment several times, so as to find the proper torque setting for the machine.

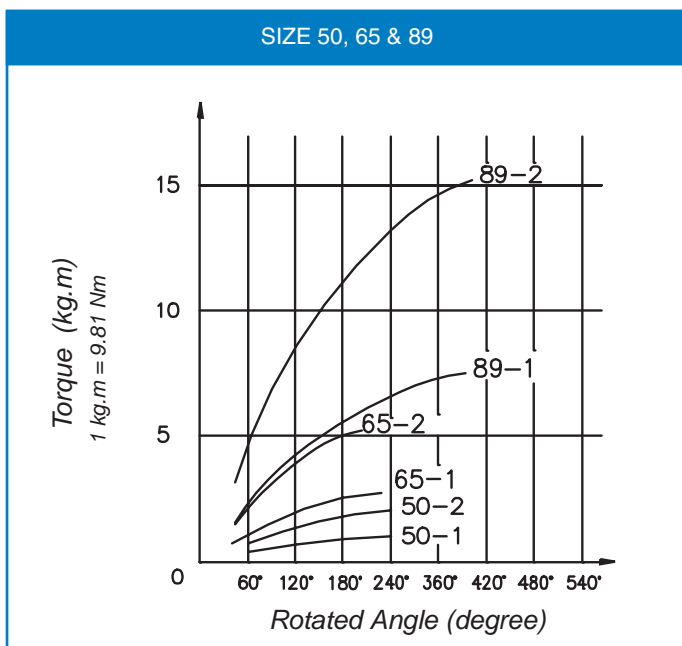

CENTRE MEMBER INFORMATION

1. So as to obtain the rated torque release and re-engagement, Challenge recommend that the centre member should be machined on its rubbing surfaces. The recommended surface finish is Ra1.6. It should also be flat, parallel, square with the bore and free from rust, scale, and oil. If these recommendations are not adhered to, the slip torque could be erratic.
2. The recommended bore that the centre member should be machined to, is shown in the table below. Also, provided is the minimum number of sprocket teeth to be used, together with the suggested bush length.

ROTATED ANGLE AND SETTING TORQUE

The chart below shows the relation between the effective rotated angle and preset torque and can be used as guidance. As an example, size 127-2 at 30kg.m (294Nm) needs a rotated angle of +260 degrees of adjustment on the bolts.

To get the precise torque setting, Challenge recommends the run-in of the torque limiter.

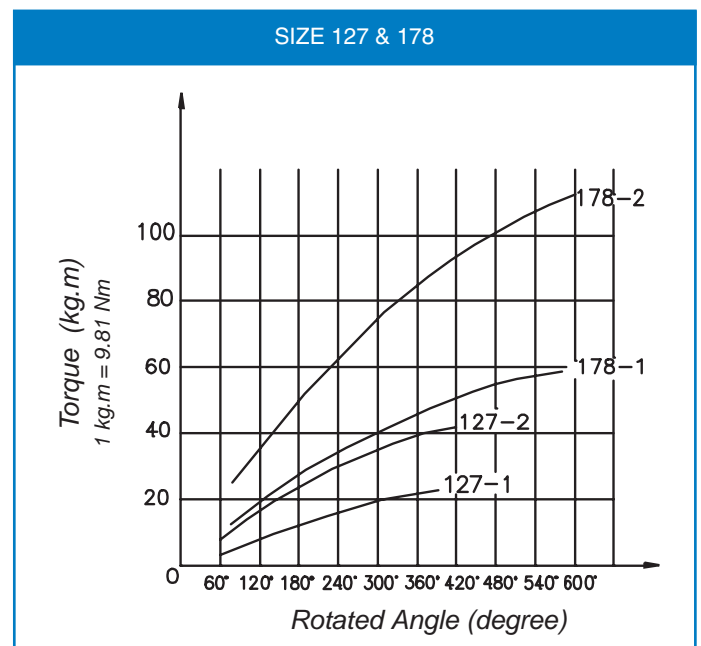

All dimensions in millimetres unless otherwise stated. Every effort has been taken to ensure that the data listed in this catalogue is correct. Challenge accepts no liability for any inaccuracies or damage caused.