

Design/installation instructions

Axial fastening

It is necessary under certain operating conditions to prop up the V-ring axially on the shaft, so as to prevent it from „creeping“

- at higher circumferential speeds (NBR >8 m/s / FKM > 6 m/s),
- at a very low expansion of the V-ring,
- when sealing oil, or
- to ease the installation (by simply complying with the specified size B after the installation)

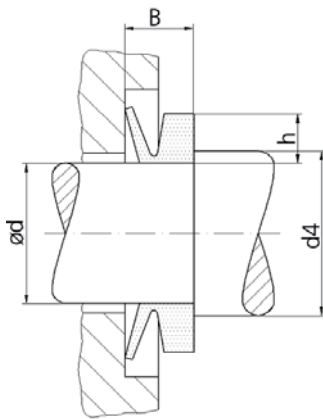

Axial fastening
 $d4 \text{ min.} = \text{ød} + 0,5 \times h$

Radial fastening

The V-ring needs to be radially fastened on the shaft in the case of higher circumferential speeds (depending on the pre-tension, NBR >12 m/s / FKM > 10 m/s). In order to do so, the V-ring can be chamfered in the area of the retaining part.

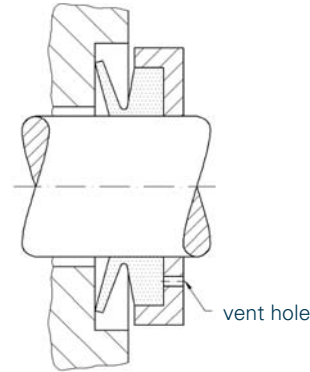

Radial fastening

Stationary application

When being used under stationary conditions, the V-ring will be installed/mounted on a non-moving part of the housing, where it seals off a surface rotating with the shaft. In such case, no centrifugal forces will act on the V-ring, thus facilitating its use above 10/12 m/s ... 20 m/s. The friction will be higher under stationary conditions, since the contact pressure of the sealing lip does not decrease while the speed rises. As compared with a rotating V-ring, the service life will therefore be limited.

The surface roughness of the counter face and the expansion of the V-ring at the inner diameter should therefore be selected accordingly low.

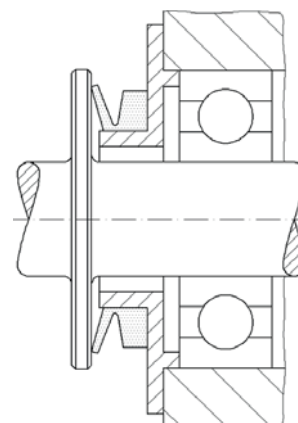

Stationary use