

Edition
2018/1

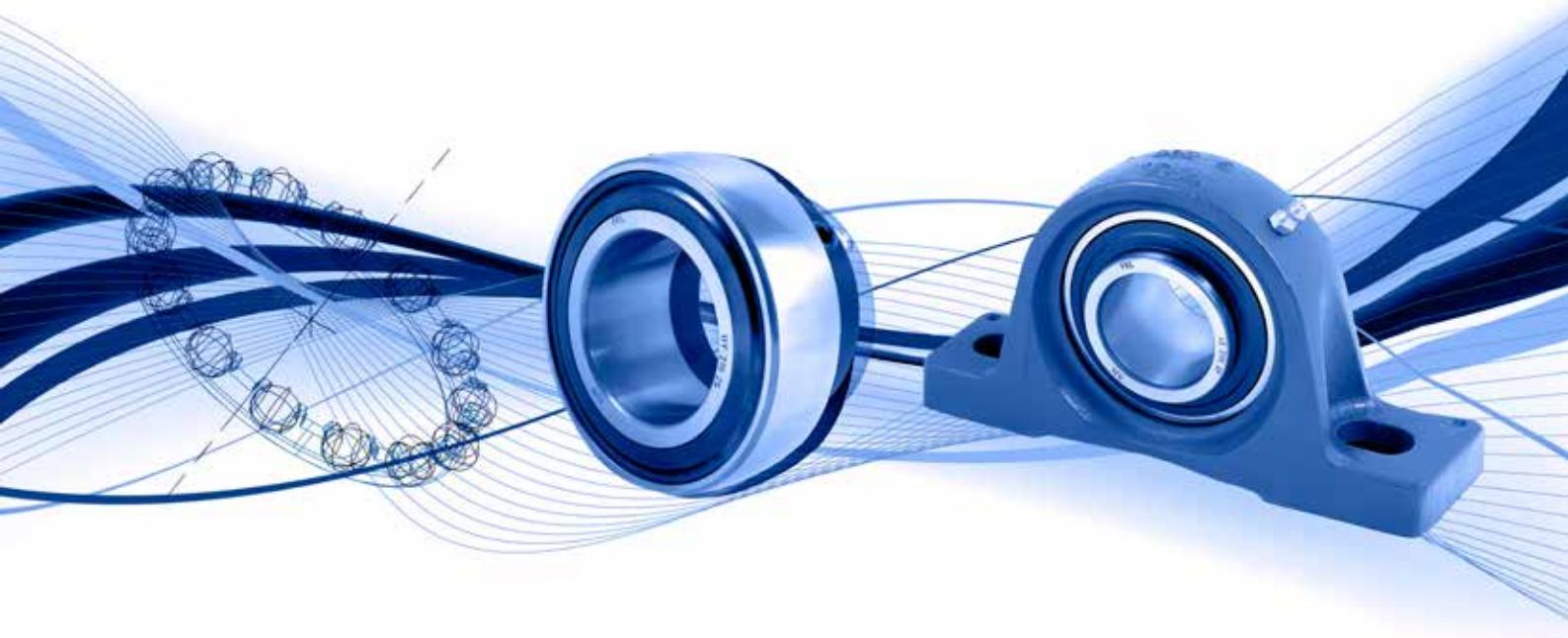

Factory of Rolling Bearings and Cardan Shafts



Product catalogue

Ball Bearings and Bearing Units



Your partner for

Providing the Best Solutions



www.fkl-serbia.com

CATALOGUE

Edition
2018/1

1. Product information

1.1. Introduction	8
1.2. Sealing.....	9
1.3. Lubrication	11
1.4. Materials	13

2. Installation

2.1. Shaft Tolerance and Speed Limit Number.....	14
2.2. Tightening.....	14

3. Y Program

3.1. Ball Bearings with Inch Bore	15
3.2. Designation System and Comparative Designation for Y-Bearings and Bearing Units.....	16
3.3. Designation Y Bearings and Bearing Units.....	17
3.3.1. Designation of Ball Bearings for Agricultural Machinery.....	21
3.4. Y Bearings Data	
3.4.1. UE.....	22
3.4.2. LE.....	24
3.4.3. UY.....	26
3.4.4. LY	28
3.4.5. UH.....	30
3.4.6. 172.....	32
3.4.7. LS; LN.....	33
3.4.8. US.....	34
3.4.09. LK.....	35
3.4.10. UK	36
3.5. Angular Contact Ball Bearing - Double Row.....	37
3.6. Y Bearing Units Data	
3.6.1. S	38
3.6.2. V	40
3.6.3. U.....	42
3.6.4. F.....	44
3.6.5. N.....	46
3.6.6. G.....	48
3.6.7. T.....	50
3.6.8. C.....	52
3.6.9. D.....	54
3.5.10. P	55



3.7. Disc Harrow Bearings First Generation	
3.7.1. Round and Square Bore Series with Spherical Outer Ring	
- Non Relubricable Type	56
3.7.2. Round and Square Bore Series with Cylindrical Outer Ring	
- Non Relubricable Type	58
3.7.3. Round and Square Bore Series – Relubricable Type	
3.7.3.1. Round Bore Series	60
3.7.3.2. Square Bore Series	62
3.7.4. Hexagonal Bore Series	64
3.8. Disc Harrow Bearing Units First Generation	
3.8.1. Square Series	66
3.8.2. Round Series	68
3.9. Disc Harrow Bearings Second Generation	70
3.10. Disc Harrow Bearings Third Generation	71
3.11. Bearing Units Type 2TB.....	72
3.12. Bearing Units Type 2TC and 2PC.....	73
3.13. ARMOR Bearing Units - Housings from Ductile Cast Iron	74
3.14. Suffixes and Prefixes	75
4. Production Program	76
5. FKL Distributors	78

Factory of Rolling Bearings and Cardan Shafts



FKL Temerin is a producer of rolling bearings and cardan shafts. The company was established in 1961, located at the area covering 13 hectares. Production area consists of two plants, covering 25 000 m².

We are proud to present at world market a wide assortment of rolling bearings and cardan shafts for industry of agriculture machines, construction machinery, business vehicles, mining equipment, processing industry, transportation equipment and other.

Fifty-year experience in manufacture, modern technology and contemporary production capacities enable product delivery according to customers demands, as well as expert help with choice of contemporary technical solutions for use of rolling bearings and cardan shafts.

During the '80s, the factory is under quick development, purchasing new, contemporary equipment and building new production workshops at a new site, in Temerin industrial zone.

Now the FKL is one of most successful factories in metal industry branch in region. From 1996, export is one of main concerns.



Mission

To reach greater business profitability and efficiency completely satisfying our customers with the highest quality and the widest range of products, which production does not affect environment. Complete orientation towards the needs and wants of our customers via continuous improvement of product quality. To be open for all of the stakeholders and buyers, distributors, and our employees.

Vision

To achieve dynamic investment cycle into the new products and technologies, as well as into widening of our product line, so that to increase our competitive advantage.



Our quality has been built on:

- QMS verified by ISO 9001, ISO 14001 and ISO 18001
- High quality raw material
- Own R&D department
- Highly productive and modernized equipment
- Qualified personnel



FKL possess own accredited laboratory for product testing



1. Product Information

1.1. Introduction

This catalog is prepared in order to present all important information about the products and their characteristics in "easy to find" manner.

Whether looking for the particular product, or solution to the specific problem. This catalog represents the choice of most frequent FKL ball bearings and cardan shafts. This is selection of products that have steady demand and are used in a wide range of applications. Our users are familiar with benefits of FKL products. This catalog is primarily designed for end users, so the technical data are reduced to a minimum.

The catalog of rolling bearings and cardan shafts includes designations and principal dimensions for all types of bearings and cardan shafts that are used to a greater or lesser extent. The catalog also includes an overview of basic production program with comparative designation. The basic designation defines the type of the bearing, size series and the diameter of the bore by the defined order. Suffixes that appear in this catalog and ones that are frequently used are listed and explained in a specified table. Designations of housings follow similar designation system and can be found in the catalog as well. Other European and worldwide producers that are not included in this catalog have similar comparative designations. Additional designations are also specified as well as other necessary explanations.

Technology utilized for the production of the bearings and cardan shafts provides significant advantages to customers due to minimal maintenance costs. Each bearing should have longer life span and should operate without any problems during the exploitation. However, it should be noted that certain external factors affect the quality of bearings as well. They should not be exposed to excessive heat and must be protected from ingress of foreign matter. Also, bearings must be properly lubricated.

This catalog presents bearings designed for agricultural equipment like combine harvesters, harrows, mowers, sugar beet harvesters... Development of the agricultural industry is followed by development of the cultivation and harvesting machinery. Each stage of cultivation requires special machinery that is either self-propelled or tractor driven, depending on operating conditions. Earlier generations of the machines were equipped with bearings that worked at lower speeds and supported lighter loads.

Modern ball bearings stand up to growing demands of operation in difficult conditions with increased productivity.

Further development trends set demands for longer exploitation life under harsh conditions and more cost-effective design for agricultural machinery. Y-bearings provide cost-effective solutions and are extensively applied in agricultural machinery production. These bearings are quick and easy to mount. Wide innerring can be mounted on the shaft by the eccentric ring, screws or adapter sleeves. Seals are specially designed and fitted to the outer ring. The advantages of these bearings have led to their rapid adoption by manufacturers of agricultural machinery.

Each FKL bearing is produced in accordance with strict premium quality standards.

1.2. Sealing

It is an economic and space-saving solution. Bearings can have shields or seals at one or both sides, those which are sealed at both sides are supplied with grease and are generally maintenance-free. Sealed bearings are generally in application where a sufficiently effective external seal cannot be provided, due to inadequate space or cost effectiveness. Bearings fitted with shields are applied where the possibility of foreign matter ingress is low and no danger of water, steam etc. coming in contact with the bearing, or where the freedom of friction of these non-contact seals is important because of the speed or operating temperature of the bearing. Bearing fitted with contact seals are preferred in application where contamination is moderate and where dampness, water, steam etc. may occur, or where a long exploitation life without maintenance is required.

1.2.1. Bearing sealing

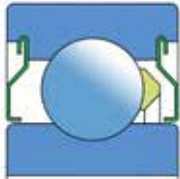

Fig. 1 Sealing ZZ

Non-contact sealing with Steel sheet shield of simple and cheap make. Grease prevents penetration of rough impurities. Allows the highest speeds. It is used with the deep groove ball bearings.

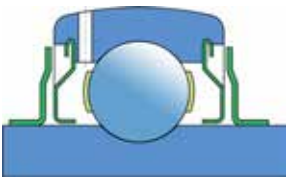

Fig. 2 Sealing 2L

Non-contact sealing improved with the sheet steel shields, which prevent the penetration of the rough impurities and lengthen the labyrinth. With the help of grease, a rather good sealing has been achieved. It permits the highest speeds. It is used with Y-bearings (special requests).

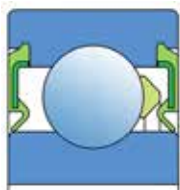

Fig. 3 Sealing ZRS

The older type of the single seal. Prevents penetration of soil, dust and water and since exposed to the impact of abrasive particles is expendable more than some new types of seals. Due to extended friction, the permitted speeds are lower. It was gradually replaced with the improved versions of (2S). Because of the traditional reasons Y bearings with this kind of seal do not have the additional sealing mark. It is used with the Y-bearings and deep groove ball bearings.

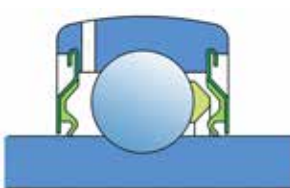

Fig. 4 Sealing 2S

Single seal with the labyrinth between the sheet part and the rubber lip which conducts the contact sealing. The friction and speeds are the same as with ZRS but provides much better protection against the rough impurity particles. This is very good sealing system: the sheet part protects the seal from the soil, dust and rough particles. At the same time makes the labyrinth with the rubber part. The rubber part provides contact sealing which prevents penetration of finer impurities, water, moisture, steam etc. Suitable for neutral conditions because of the presence of the foreign materials. It is used with the Y bearing (standard) and deep groove ball bearings.

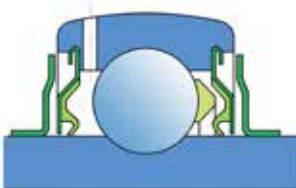

Fig. 5 Sealing 2F

Dual sealing, protection cover placed on the inner ring protects against rough impurity particles and makes the labyrinth with the sheet part of the seal; then the sealing 2S type, with the labyrinth between the sheet part and the rubber lip that conducts the contact sealing. The friction and speeds are the same as with 2S but has much better protection against rough impurity particles. It is very good sealing system: the sheet part protects the seal from the soil, dust and rough particles. At the same time makes the labyrinth with the rubber part. The rubber part provides the contact sealing that prevents the penetration of the finer impurities, water, moisture, steam etc. Suitable for heavier conditions due to better protection against foreign matters. It is used with the Y bearings (standard).

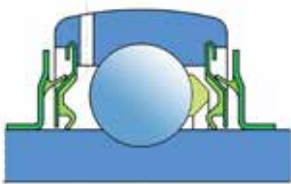

Fig. 6 Sealing 2B

Dual contact sealing, design similar to 2F but protection cover has rubber lip resting on the sheet part of the inner contact seal providing an additional protection against the penetration of the finer impurities, water, moisture, steam etc. The friction is larger than with 2F and permitted speeds are about 50% lower. It is used with the Y bearings (delivery is made according to special request).

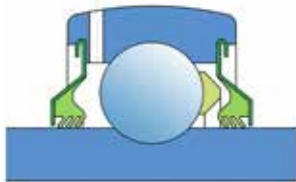

Fig. 7 Sealing 2T

By construction is the same as 2S, except rubber lip is tripled. Therefore, it seals better but has even larger friction. The permitted speeds are much lower, up to 500 rpm. It emerges out of external ring width and is applied only with special bearings for the agricultural machines (practically standard sealing for the disc harrow bearings) and to the less extent, Y - bearing program (delivery is made according to special request).

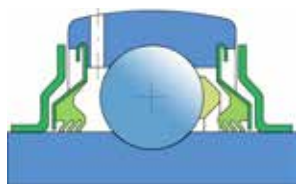

Fig. 8 Sealing 2TB

Dual sealing, combination 2T and stronger protection steel. Friction and speeds are the same as 2T, but considerably better protection against rough dirt. This type of sealing is applied in agricultural machinery. Protection steel protects from soil, dust, rough dirt and mechanical impact on the seal. Triple-lips seal performs contact sealing that prevents penetration of finer dirt, water, damp etc. Suitable for difficult working conditions with aggressive presence of foreign matter. Used with Y bearing units 2TB.



Fig. 9 Sealing 2P

By construction is the similar as 2T, except rubber lip is fivefold. Therefore, it seals better but has even larger friction. The permitted speeds are much lower, up to 500. It emerges out of external ring width and is applied only with special bearings for the agricultural machines (practically standard sealing for the disc harrow bearings) and to the less extent, Y - bearing program (delivery is made according to special request).



Fig. 10 Sealing 2PB

Dual sealing, combination 2P and stronger protection steel. Friction and speeds are the same as 2P, but considerably better protection against rough dirt. This type of sealing is applied in agricultural machinery. Protection steel protects from soil, dust, rough dirt and mechanical impact on the seal. Five lip seal performs contact sealing that prevents penetration of finer dirt, water, damp etc. Suitable for difficult working conditions with aggressive presence of foreign matter. Used with Y bearing units according to special request.



Fig. 11 Sealing TDT

Additional metal cover with thickness of 1 mm provides reliable mechanical protection. Unique combination of six-lip sealing, double 3 lip sealing protects bearing from the outer side, one 3 lip sealing protects bearing from inner side. This presents today the best sealing system for application in agricultural machinery.

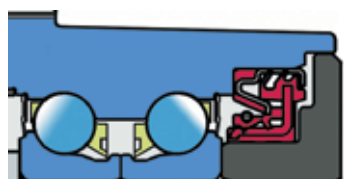

Fig. 12 Cassette Sealing

Designed for hard working condition at unfriendly environment. Half metal - half rubber outside diameter provides reliable seal retention in the bore and improves sealing performance. Inside diameter is covered by rubber and improves sealing performance and easy installation. This sealing provides maximum protection against liquid or solid contaminants, which significantly extends bearing service life.

1.3. Lubrication

FKL bearings and bearing units with integral seals and shields at both sides are sufficiently greased for the lifetime and should not be lubricated, except when used in very harsh working conditions. Standard greases used by FKL in those products have optimal temperature range and other characteristics suitable for the intended application areas. Filling grades correspond to the bearing size. Relubrication is possible with Y bearings and bearing units supplied with lubricators and corresponding grease channels. FKL sealed bearings are filled with lithium-grease consistency 2 and cinematic viscosity of basic, mineral oil around 90 mm²/s; temperature range of application ranges from -30 up to +120°C.

1.3.1. Grease lubrication

About 90% of all bearing arrangements are lubricated with grease. Grease has certain advantage comparing to oil because it is easier to retain in the bearing arrangement, particularly with inclined or vertical shafts, and also improves sealing the arrangement against contaminants, moisture or water. However, the shortcoming is lower speeds comparing to oil lubrication. With higher speed bearings, the excess lubricant would cause rapid rise of operating temperature. As a general rule, therefore only the bearing should be completely filled, whilst the free space in the housing should be greased between 30 and 50%. Where the bearings are to operate at very low speed and must be well protected against corrosion, it is advisable to completely fill the housing with grease.

1.3.1.1. Lubricating greases

Lubricating greases consist of mineral or synthetic oil combined with a thickener. The thickeners are usually metallic soaps. Additives can also be included to enhance certain characteristics of the grease. The consistency of the grease depends largely on the type and concentration of used thickener. When selecting grease, the viscosity of the base oil, the consistency, operating temperature range and the load carrying ability are the most important factors to be considered.

Base oil viscosity

The base oil viscosity of the greases normally used for rolling bearings lies between 15 and 500 mm²/s at 40°C. Greases based on oils having higher viscosities than 1000 mm²/s at 40°C bleed oil so slowly that the bearing will not be adequately lubricated. Therefore, if a very high viscosity is required because of low speeds, oil lubrication will generally be found more reliable. The base oil viscosity also governs the maximum permissible speed at which given grease can be used for bearing lubrication. For applications

operating at very high speeds, the most suitable greases are those incorporating diester oils of low viscosity. The permissible operating speed for grease is also influenced by the shear strength of the grease, which is determined by the thickener. A speed factor $A=n \times d_m$ is often quoted by grease manufacturers to indicate the speed capability; n is the rotational speed and d_m is the bearing mean diameter - $d_m=0,5(d+D)$.

Consistency

Greases are divided into various consistency classes (DIN 51 818), according to the National Lubricating Grease Institute (NLGI) Scale. The consistency of greases used for bearing lubrication should not change unduly according to temperature within the operating temperature range or due to mechanical operation. Greases that soften at elevated temperatures may leak from the bearing arrangement. Those that stiffen at low temperatures may restrict rotation of the bearing. Metallic soap thickened greases of consistency 1, 2 or 3 are those normally used for rolling bearings. The consistency 3 greases are primarily recommended for bearing arrangements with vertical shafts.

Protection against corrosion

The grease rust inhibiting characteristics are mainly determined by the rust inhibitors which are added to the grease and its thickener. Grease should provide protection to the bearing against corrosion and should not be washed out of the bearing in case of water penetration. These two features are possessed by lithium and calcium based greases containing lead base additives. However, because of environmental and health reasons such additives are being replaced by other combinations of additives which do not always provide lubricant with such good features.

Load carrying ability

For heavily loaded bearings, e.g. rolling mill bearings, it has been accustomed to recommend the use of greases containing EP additives, since those additives increase the load carrying ability of the lubricant film. Originally, most EP additives were lead-based compounds and there were arguments suggesting benefits in bearing life extension where lubrication was otherwise poor without elastic-hydrodynamic lubricant film.

Miscibility

Some greases are incompatible and if mixed together the consistency can change dramatically as well as allowed operating temperature. Greases having the same thickener and similar base oils can generally be mixed without any consequences. Lithium and calcium base greases are generally miscible with each other but not with sodium base greases. However, mixtures of compatible greases may have a consistency which is less than either of the component greases, although the lubricating characteristics are not necessarily impaired. In bearing arrangements where a low consistency might lead to grease leakage from the arrangement, the next relubrication should involve complete replacement of the grease rather than replenishment.

1.3.1.2. Relubrication

Rolling bearings have to be relubricated if the operating life of the used grease is shorter than the expected life span of the bearing. Relubrication should be performed while lubrication of the bearing is still satisfactory. The time at which relubrication should be undertaken depends on many factors which are related in a complex manner. Those include bearing type and size, speed, operating temperature, grease type, space around the bearing and the bearing environment. The following information is based on long-term tests in various applications but does not apply to applications where water and/or solid contaminants can penetrate the bearing arrangement. In such cases it is recommended that the grease is frequently renewed in order to remove contaminants from the bearing.

Relubrication intervals

Relubrication intervals t_1 , for normal operating conditions can be calculated as a function of bearing speed n and bore diameter d of a certain bearing type from Diagram 1. The diagram is valid for bearings on horizontal shafts in stationary machines under normal loads. It applies to good quality lithium base greases at a temperature not exceeding 70°C. To calculate accelerated ageing of grease due to increased temperature it is recommended to split intervals obtained from the diagram by half for every 15°C increase in bearing temperature above 70°C. The intervals may be extended at temperatures lower than 70°C but as operating temperatures decrease the grease will bleed oil less readily and with lower temperatures the extension of intervals by more than two times is not recommended. For bearings on vertical shafts the intervals obtained from the diagram (t_1) should be halved. For large roller bearings having d of 300 mm and above, the high specific loads in the bearing mean that adequate lubrication will be obtained if the bearing is more frequently relubricated than indicated by the diagram, and the lines are therefore

broken. It is recommended in such cases when continuous lubrication is practiced for technical and economic reasons. The grease quantity to be supplied can be obtained from the equation below:

$$G_k = (0,3 \dots 0,5) D B 10^{-4}$$

where

G_k - grease quantity to be continuously supplied, g/h

D - bearing outside diameter, mm

B - total bearing width (for thrust bearings use total height H), mm

Relubrication procedures

One of the two procedures described below should be used, depending on the relubrication interval t_1 obtained:

1. If the relubrication interval is shorter than 6 months, then it is recommended that the grease filling the bearing arrangement should be replenished (topped up) at intervals corresponding to 0,5 t_1 , the complete grease fill should be replaced after three replenishments, at the latest. Suitable quantities for replenishment can be obtained from

$$G_p = 0,005 D B$$

where

G_p - grease quantity to be added when replenishing, g

D - bearing outside diameter, mm

B - total bearing width (for thrust bearings use total height H), mm

2. When lubrication intervals are longer than 6 months it is recommended that all used grease should be removed from the bearing arrangement and replaced by fresh grease.

All these are rough guidelines if there are no specific recommendations by the manufacturer or maintenance service. To facilitate the supply of grease using a grease gun, a grease nipple should be provided on the housing. It is also necessary to provide an exit hole for the grease so that excessive amounts would not build up in the bearing surrounding space. Otherwise it might cause permanent increase in the bearing temperature.

However, as soon as the appropriate temperature is reached after relubrication, the exit hole should be plugged or clogged so the oil bled by the grease could remain at the bearing position. The danger of excess grease collection in the space surrounding the bearing, causing temperature peaking with its detrimental effect on the grease as well as the bearing, is most emphasized when bearing

operates at high speeds. In such cases it is advisable to use a grease discharge valve rather than an exit hole. A grease discharge valve consists basically of a disc which rotates with the shaft and forms a narrow gap with the housing end cover. Excess and used grease is thrown out by the disc into an annular cavity and leaves the housing through an opening on the bottom side of the end cover. To ensure the fresh grease actually reaches the bearing and replaces the old grease, lubrication duct in the housing should either feed the grease adjacent to the outer ringside face or, into the bearing tracks. In general, one should pay

attention to grease density and that it does not remain within the bearing.

1.3.2. Bearing storage

When bearings are stored in their original packaging, they are corrosion protected for several years. Warehouse humidity should not exceed 60%. In case of sealed bearings, if kept in stock for a long period of time, grease may solidify so after the bearing is mounted, its friction moment is higher in comparison to new bearings. Therefore, this should be taken into consideration.

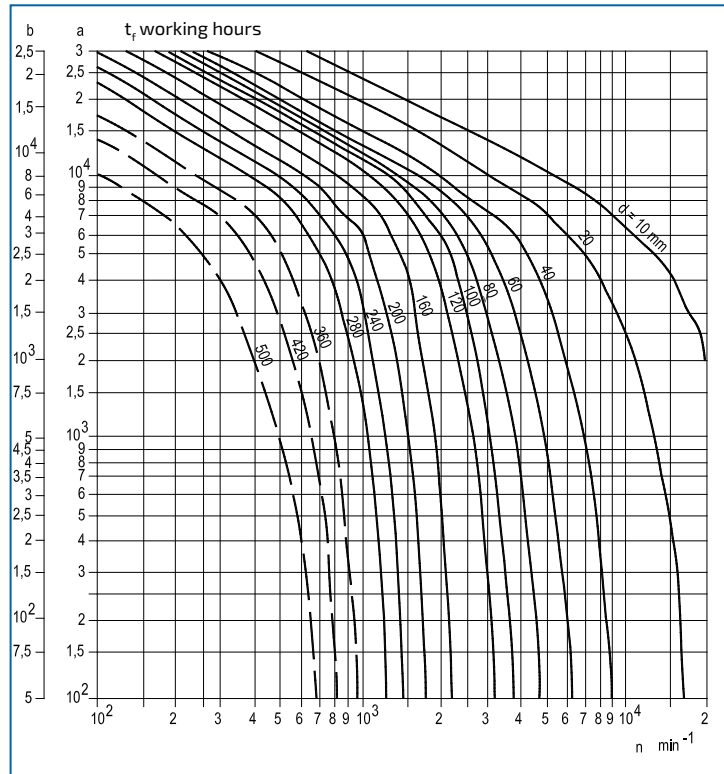

Diagram 1. Relubrication interval

Scale a: deep groove ball bearings

Scale b: cylindrical roller bearings, needle bearings

Scale c: spherical, taper roller bearings, thrust ball bearings

roller bearings – full complement (0,2 t_r),

cross-roller bearings with cage (0,3 t_r)

thrust roller, needle, spherical bearings (0,5 t_r)

1.4. Materials

The rings of the bearings and rolling elements are made of special steel (100Cr6 by ISO 683-17:1999) manufactured by the method of vacuum degasification. They are exposed to heat treatment to retain dimensions stability to 150°C. The cages for standard operating temperatures (-20 to +120°C) are made of plastic (ULTRAMID A4H, POLYAMIDE 66). The positive effects of POLYAMIDE, elasticity and small weight, are evident on the high impact bearing load and negative acceleration. The cages of POLYAMIDE possess very good sliding characteristics and steady operation.

The pressed cages are made out of steel sheet. Some massive cages are made of brass. The seals are rubber made (PERBUNAN, BUNA M) and vulcanized onto the sheet guard plate. They can operate in temperature range from -20 to +120°C. Flingers are made of steel sheet. T housings of the Y-bearings are made of cast iron, hardness 200 HB or cold-rolled steel sheet. Grease for common operation temperatures (between -20 and +120°C) is lithium base grease, consistency of the grease 2, viscosity at 40°C is 90 mm²/s.

2. Installation

2.1. Shaft Tolerance and Speed Limit Number

Speed ratings

Speed is limited by two factors:

1. By the shaft tolerance on which the bearing is mounted; as tighter fitting is more resistant to shock loads and vibrations and vice versa, fitting with greater clearance is sensitive to those influences and lower speed can be allowed. Recommendations for speed rating, depending on the shaft tolerance, are shown in the Table 1.

2. By the type of sealing because the friction between the sealing and bearing ring increases the operating temperature in proportion to the speed. For normal sealing 2S and 2F data are shown in the following table. For sealing 2B allowed speed is 55 - 60% from that given in the table.

For bearings with three-lip sealing 2T, 2TB and 2TC (bearings for agricultural machinery) allowed speed is max. 500 rpm unless it is lower according to the Table 1.

Bearing type → Shaft diameter d	UE, LE, UY, LY Shaft tolerances						LK	1726..., LS
	m7, k7	h6	h7	h8	h9	h11		
12	12000	9500	6000	4300	1500	950	-	14000
15	12000	9500	6000	4300	1500	950	-	13000
17	12000	9500	6000	4300	1500	950	-	12000
20	10000	8500	5300	3800	1300	850	7000	10000
25	9000	7000	4500	3200	1000	700	6300	10000
30	7500	6300	4000	2800	900	630	5300	7500
35	6300	5300	3400	2200	750	530	4800	6300
40	5600	4800	3000	1900	670	480	4300	5600
45	5300	4300	2600	1700	600	430	4000	5000
50	4800	4000	2400	1600	560	400	3600	4800
55	4300	3600	2000	1400	500	360	3400	-
60	4000	3400	1900	1300	480	340	3000	-
65	3600	3000	1700	1100	430	300	2600	-
70	3300	2800	1600	1000	400	280	2400	-
80	2800	2400	1400	900	360	240	2200	-
90	2400	2000	1200	800	320	200	-	-
100	2200	1900	1100	750	300	190	-	-
120	1900	1700	900	600	250	160	-	-

Table 1. Speed ratings for Y bearings

2.2. Tightening

Axial load carrying capacity

Tightening torques for grub screws locking the bearings on the shaft, as well as axial load capacity of shaft-bearing connections are shown in the Table 2.

Shaft diameter (mm)	up to 20	25	30	35	40	45	50	55	60	65	70	75	80	85	90	100	120
Tightening torque (Nm)	4	5	6	12	12	12	23	23	23	23	23	23	23	23	23	23	23
Hook spanner (mm)	3	3	3	4	4	4	5	5	5	5	5	5	6	6	6	6	6
Axial load (kN)	2	3	4	5	6	8	9	10	12	14	14	15	16	16	16	16	16

Table 2. Axial load carrying capacity

3. Y Program

3.1. Ball Bearings with Inch Bore

Hole in Inch	Numerical Designation		Hole in mm
	old	new	
1/2"	201-8	201-008	12,700
9/16"	202-9	202-009	14,2875
5/8"	202-10	202-010	15,8750
11/16"	203-11	203-011	17,6425
3/4"	204-12	204-012	19,0500
13/16"	204-13	205-013	20,6375
7/8"	205-14	205-014	22,2250
15/16"	205-15	205-015	23,8125
1"	205-16	205-100	25,4000
1-1/16"	206-17	206-101	26,9875
1-1/8"	206-18	206-102	28,5750
1-3/16"	206-19	206-103	30,1625
1-1/4"	206-20	206-104	31,7500
1-1/4"	207-20	207-104	31,7500
1-5/16"	207-21	207-105	33,3375
1-3/8"	207-22	207-106	34,9250
1-7/16"	207-23	207-107	36,5125
1-1/2"	208-24	208-108	38,1000
1-9/16"	208-25	208-109	39,6875
1-5/8"	209-26	209-110	41,2750
1-11/16"	209-27	209-111	42,8625
1-3/4"	209-28	209-112	44,4500
1-13/16"	209-29	209-113	46,0375
1-7/8"	210-30	210-114	47,6250
1-15/16"	210-31	210-115	49,2125
2"	211-32	211-200	50,8000
2-1/16"	211-33	211-201	52,3875
2-1/8"	211-34	211-202	53,9750
2-3/16"	211-35	211-203	55,5625
2-1/4"	212-36	212-204	57,1500
2-5/16"	212-37	212-205	58,7375
2-3/8"	212-38	212-206	60,3250
2-7/16"	212-39	212-207	61,9125
2-1/2"	213-40	213-208	63,5000
2-9/16"	214-41	214-209	65,0875
2-5/8"	214-42	214-210	66,6750
2-11/16"	214-43	214-211	68,2625
2-3/4"	214-44	214-212	69,8500
2-13/16"	214-45	214-213	71,4375
2-7/8"	215-46	215-214	73,0250
2-15/16"	215-47	215-215	74,6125
3"	215-48	215-300	76,2000
3-1/16"	215-49	215-301	77,7875
3-1/8"	216-50	216-302	79,3750
3-3/16"	216-51	216-303	80,9625
3-1/4"	217-52	217-304	82,5500
3-5/16"	217-53	217-305	84,1375
3-3/8"	217-54	217-306	85,7250
3-7/16"	217-55	217-307	87,3125
3-1/2"	218-56	218-308	88,9000
3-9/16"	218-57	218-309	90,4875
3-5/8"	218-58	218-310	92,0750
3-11/16"	218-59	218-311	93,6625
3-3/4"	220-60	220-312	95,2500
3-13/16"	220-61	220-313	96,8375
3-7/8"	220-62	220-314	98,4250
3-15/16"	220-63	220-315	100,0125
4"	220-64	220-400	101,6000

3.2. Designation System and Comparative Designation for Y Bearings and Bearing Units



LEGENDA

FKL
SKF
FAG
INA
SNR
NSK
NTN

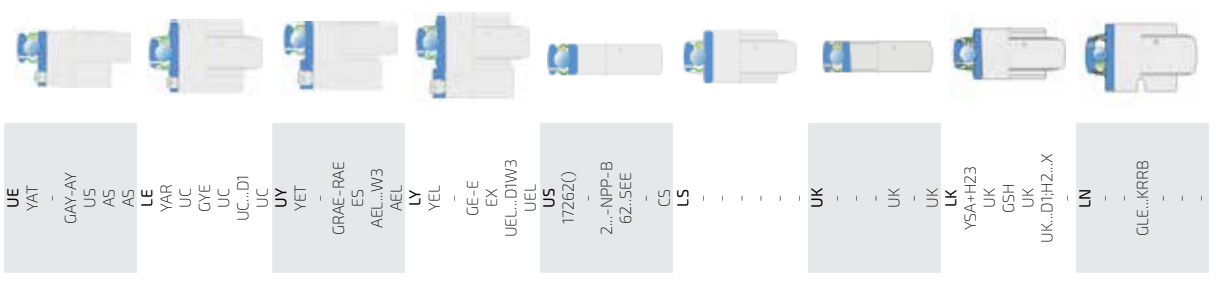

S	V	U	F	N	G	T	C	D	P
SY(O) P GG,ASE P,PE P...D1 P	SYFJ - PA UP...D1 UP	SYF PA GG,SHE PAE -	FY(O) F GG,CJ F F...D1 F	FYT FL GG,CJT FL FL...D1 FL	FYC FC GG,ME FC FC...D1 FC	TU T GG,TUE T T...D1 T	FLAN...MSB PF PF PF	FLAN...MSTR/ LSTR PFT PFT	PFT - FLAN...MST PFL PFL PFL
UES	UEV	UEU	UEF	UEN	UEG	UET	UEC	UED	UEP
SY(O),RM	SYFL,RM	SYFERM	FY,RM	FYT(O),RM	FYC,RM	TU,RM	PF,RM	PF,D,RM	PFTRM
PA5EY USP USPE	USPA	PSHEY USPAE	PCY USF	PCJTY USFL	PMEY USFC	PTUEY UST	RAY USPF	RATY USPFT	RATY USPFL
ASP	ASUP	ASP	ASF	ASFL	ASFL	LET	LEP	LEP	ASPFL
LES	LEV	LEU	LEF	LEN	LEG	TU,TF	LET	LET	LEP
SY(O),TF	SYFJ,TF	SYFJ,TF	FY(O),TF	FYT(O),TF	FYC,TF	TU,TF	PE,TF	PE,TF	PE,TF
UCP	UCPA	UCPA	UCF	UCFL	UCFC	UCT	GRRY	UCT	UCT
RASEY	RSHEY	RSHEY	RCY	RCJTY	RMEY	RTUEY	UCT	UCT	UCT
UCP,UCPE	UCPAE	UCPAE	UCF	UCFL	UCFC	UCT	UCT	UCT	UCT
UCP...D1	UCUP...D1	UCPAE	UCF...D1	UCFL...D1	UCFC...D1	UCT...D1	UCT	UCT	UCT
UCP	UCUP	UCP	UCF	UCFL	UCFC	UCT	UCT	UCT	UCT
UY5	UYV	UYU	UYF	UYN	UYG	UYT	UYC	UYD	UYP
SY(O),FM	SYFJ,FM	SYFJ,FM	FY(O),FM	FYT,FM	FYC,FM	TU,FM	PF,FM	PF,D,FM	PFTR,FM
PA5E ESP ESPE	ESPA	PSHE ESPAE	PCJ ESF	PCJTY ESFL	PME ESFC	PTUE EST	GRA-RA ESPFL	RATR ESPFT	RAT ESPFL
AELP	AELUP	AELP	AELF	AELFL	AELFC	AELT	AELPF	AELPF	AELPFL
LY5	LYV	LYU	LYF	LYN	LYG	LYT	LYC	LYD	LYP
SY(O),WF	SYFJ,Wf	SYF,Wf	FY(O),WF	FYT,Wf	FYC,Wf	TU,Wf	PE,Wf	PE,Wf	PE,T,Wf
RASE EXP EXPE	RSHE EXPAE	RSHE EXPAE	RCJ EXF	RCJTY EXFL	RME EXFC	RTUE EXT	RRTR	RRTR	RRTR
UELUP...D1W3	UELUP...D1W3	EXPAE	UEL...D1W3	UEL...D1W3	UELFC...D1W3	UEL...D1W3	UEL...D1W3	UEL...D1W3	UEL...D1W3
UEL	UELUP	UEL	UELF	UEFL	UELFC	UEL	UEL	UEL	UEL
US5	USV	USU	USF	USN	USG	UST	USC	USD	USP
LS5	LSV	LSU	LSF	LSN	LSG	LST	LSC	LSD	LSP
UK5	UKV	UKU	UKF	UKN	UKG	UKT	UKC	UKD	UKP
SY(O),KF	SYFJ,KF	SYF,KF	FY(O),KF	FYT(O),KF	FYC,KF	TU,KF	UKC	UKD	UKP
UKP	UKPA	UKPAE	UKF	UKFL	UKFC	UKT	UKC	UKD	UKP
UKP	UKPA	UKPAE	UKF	UKFL	UKFC	UKT	UKC	UKD	UKP
UKS	UKV	UKU	UKF	UKN	UKG	UKT	UKC	UKD	UKP
SY(O),KF	SYFJ,KF	SYF,KF	FY(O),KF	FYT(O),KF	FYC,KF	TU,KF	UKC	UKD	UKP
RASEA	UKP,UKPE	UKPAE	UKF	UKFL	UKFC	UKT	UKC	UKD	UKP
UKP...D1H2...X	UKUP...D1H2...X	UKPAE	UKF...D1H2...X	UKFL...D1H2...X	UKFC...D1H2...X	UKT...D1H2...X	UKPFT	UKPFT	UKPFL
UKP	UKUP	UKU	UKF	UKFL	UKFC	UKT	UKP	UKD	UKP
LN5	LNW	LNW	LNW	LNW	LNW	LNT	LNC	LND	LNP
RA5EL	RA5EL	RA5EL	RA5EL	RA5EL	RA5EL	RA5EL	RA5EL	RA5EL	RA5EL
GLE...KRRB	GLE...KRRB	GLE...KRRB	GLE...KRRB	GLE...KRRB	GLE...KRRB	GLE...KRRB	GLE...KRRB	GLE...KRRB	GLE...KRRB

3.3. Designation Y Bearings and Bearing Units

Y-bearing units represent the main FKL production program, which is characterized by:

- Compatibility with ISO standards
- Market/customer focused range
- Premium quality products and reliable delivery service

How to use this publication

1. Select the bearing type
2. Select the housing design
3. Check that the selected unit is in the „Y-units“
4. Determine the unit designation



S	V
203-204-205-206 207-208-209-210 211-212-213-214 215-216-218-220	204-205-206-207 208-209-210

UES 12-15-17-20-25 30-35-40-45-50 mm bore	UEV 20-25-30-35-40 45-50 mm bore	UE		UE 2 Size: 03/12-03/15-03-04-05-06-07-08-09-10 - Inner ring extended on one side only - Grub screw locking - Seals: Metal-rubber seal - Long life lithium/calcium grease
LES 12-15-17-20-25 30-35-40-45-50 55-60-65-70-75 80-90-100 mm bore	LEV 20-25-30-35-40 45-50 mm bore	LE		LE 2 Size: 03/12-03/15-03-04-05-06-07-08-09-10-11-12 13-14-15-16-17-18-20-24 - Inner ring extended on both sides - Grub screw locking - Seals: Metal-rubber seal + metal shield - Long life lithium/calcium grease

Y-Bearings and Bearing Units



S	V	U	F	N
203-204-205-206 207-208-209-210 211-212-213-214 215-216-218-220	204-205-206-207 208-209-210	206-207-208-209- 210	203-204-205-206 207-208-209-210 211-212-213-214 215-216-218-220	203-204-205-206 207-208-209-210 211
UES 12-15-17-20-25 30-35-40-45-50 mm bore	UEV 20-25-30-35-40 45-50 mm bore	UEU 30-35-40-45-50 mm bore	UEF 12-15-17-20-25 30-35-40-45-50 mm bore	UEN 12-15-17-20-25 30-35-40-45-50 mm bore
LES 12-15-17-20-25 30-35-40-45-50 55-60-65-70-75 80-90-100 mm bore	LEV 20-25-30-35-40 45-50 mm bore	LEU 30-35-40-45-50 mm bore	LEF 12-15-17-20-25 30-35-40-45-50 55-60-65-70-75 80-90-100 mm bore	LEN 12-15-17-20-25 30-35-40-45-50 55 mm bore
UYS 12-15-17-20-25 30-35-40-45-50 55-60 mm bore	UYV 20-25-30-35-40 45-50 mm bore	UYU 30-35-40-45-50 mm bore	UYF 12-15-17-20-25 30-35-40-45-50 55-60 mm bore	UYN 12-15-17-20-25 30-35-40-45-50 55 mm bore
LYS 12-15-17-20-25 30-35-40-45-50 55-60-65-70-75 80-90-100 mm bore	LYV 20-25-30-35-40 45-50 mm bore	LYU 30-35-40-45-50 mm bore	LYF 12-15-17-20-25 30-35-40-45-50 55-60-65-70-75 80-90-100 mm bore	LYN 12-15-17-20-25 30-35-40-45-50 55 mm bore
USS 17-20-25-30-35 40-45-50-55-60 mm bore	USV 20-25-30-35-40 45-50 mm bore	USU 30-35-40-45-50 mm bore	USF 17-20-25-30-35 40-45-50-55-60 mm bore	USN 17-20-25-30-35 40-45-50-55 mm bore
LSS 25-30-35-40-45 50-55 mm bore	LSV 25-30-35-40-45 50 mm bore	LSU 30-35-40-45-50 mm bore	LSF 25-30-35-40-45 50-55 mm bore	LSN 25-30-35-40-45 50-55 mm bore
UKS 25-30-35-40-45 50-55 mm bore	UKV 25-30-35-40-45 50 mm bore	UKU 30-35-40-45-50 mm bore	UKF 25-30-35-40-45 50-55 mm bore	UKN 25-30-35-40-45 50-55 mm bore
LKS 25-30-35-40-45 50-55-60-65-75 80 mm bore	LKV 25-30-35-40-45 50 mm bore	LKU 30-35-40-45-50 mm bore	LKF 25-30-35-40-45 50-55-60-65-75 80 mm bore	LKN 25-30-35-40-45 50-55 mm bore

Y-Bearings and Bearing Units



G

T

C

D

P

204-205-206-207
208-209-210-211
212-213

204-205-206-207
208-209-210-211

204-205-206-
207-208

205-206-207

204-205-206-207-
208

UEG

20-25-30-35-40
45-50

mm bore

UET

20-25-30-35-40
45-50

mm bore

UEC

20-25-30-35-40

mm bore

UED

20-25-30-35

mm bore

UEP

20-25-30-35-40

mm bore

LEG

20-25-30-35-40
45-50-55-60-65

mm bore

LET

20-25-30-35-40
45-50-55

mm bore

LEC

20-25-30-35-40

mm bore

LED

20-25-30-35

mm bore

LEP

20-25-30-35-40

mm bore

UYG

20-25-30-35-40
45-50-55-60

mm bore

UYT

20-25-30-35-40
45-50-55

mm bore

UYC

20-25-30-35-40

mm bore

UYD

20-25-30-35

mm bore

UYP

20-25-30-35-40

mm bore

LYG

20-25-30-35-40
45-50-55-60-65

mm bore

LYT

20-25-30-35-40
45-50-55

mm bore

LYC

20-25-30-35-40

mm bore

LYD

20-25-30-35

mm bore

LYP

20-25-30-35-40

mm bore

USG

20-25-30-35-40
45-50-55-60

mm bore

UST

20-25-30-35-40
45-50-55

mm bore

USC

20-25-30-35-40

mm bore

USD

17-20-25-30-35

mm bore

USP

20-25-30-35-40

mm bore

LSG

25-30-35-40-45
50-55

mm bore

LST

25-30-35-40-45
50-55

mm bore

LSC

25-30-35-40

mm bore

LSD

25-30-35

mm bore

LSP

25-30-35-40

mm bore

UKG

25-30-35-40-45
50-55-60-65

mm bore

UKT

25-30-35-40-45
50-55

mm bore

LKG

25-30-35-40-45
50-55-60-65

mm bore

LKT

25-30-35-40-45
50-55

mm bore

Y-Bearings and Bearing Units

UE



UE 2..

Size: 03/12-03/15-03-04-05-06-07-08-09-10

- Inner ring extended on one side only
- Grub screw locking
- Seals: Metal-rubber seal
- Long life lithium/calcium grease

LE



LE 2..

Size: 03/12-03/15-03-04-05-06-07-08-09-10-11-12-13-14-15-16-17-18-20-24

- Inner ring extended on both sides
- Grub screw locking
- Seals: Metal-rubber seal + metal shield
- Long life lithium/calcium grease

UY



UY 2..

Size: 03/12-03/15-03-04-05-06-07-08-09-10-11-12

- Inner ring extended on one side only
- Eccentric locking collar
- Seals: Metal-rubber seal
- Long life lithium/calcium grease

LY



LY 2..

Size: 03/12-03/15-03-04-05-06-07-08-09-10-11-12-13-14-15-16-18-20-24

- Inner ring extended on both sides
- Eccentric locking collar
- Seals: Metal-rubber seal + metal shield
- Long life lithium/calcium grease

UH



UH 2..

Size: 05-06-07-08-09

- Bore reduced one size by adapter sleeve
- Standard adapter sleeve series H3(00)
- Seals: Metal-rubber seal
- Long life lithium-calcium grease
- Bearing and adapter sleeve to be ordered together

LS



LS 2..

Size: 05-06-07-08-09-10-11

- Inner ring extended on both sides
- Locking by interference on the shafts
- Seals: Metal-rubber seal + metal shield
- Long life lithium/calcium grease

LN



LN 2..

Size: 04-06-07

- Drive slot in inner ring
- Inner ring extended on both sides
- Seals: Metal-rubber seal + metal shield
- Long life lithium/calcium grease

US



US 2..

Size: 03-04-05-06-07-08-09-10-11-12

- Inner ring and outer ring same width
- Locking by interference on the shaft
- Seals: Metal-rubber seal
- Long life lithium/calcium grease

LK



LK 2..+H...

Size: 05-06-07-08-09-10-11-12-13-14-15-16-17-18

- Bore reduced one size by adapter sleeve
- Standard adapter sleeve series H23 (00)
- Seals: Metal-rubber seal + metal shield
- Long life lithium/calcium grease
- Bearing and adapter sleeve to be ordered separately

UK







UK 2..+H...

Size: 05-06-07-08-09-10-11-12-13-14-15-16-17-18

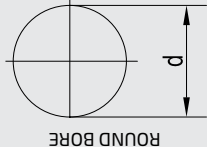
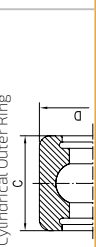
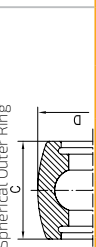
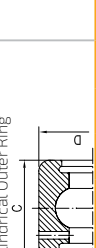
- Bore reduced one size by adapter sleeve
- Standard adapter sleeve series H23 (00)
- Seals: Metal-rubber seal
- Long life lithium/calcium grease
- Bearing and adapter sleeve to be ordered separately

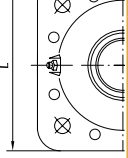
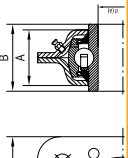
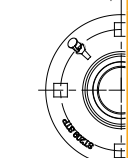
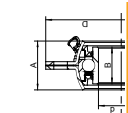
3.3.1. Designation of Ball Bearings for Agricultural Machinery

BALL BEARINGS FOR AGRICULTURAL MACHINERY				BEARING UNITS						
Inner Ring	Permanently Lubricated		With Lubrication Groove		BEARING UNITS					
	Cylindrical Outer Ring	Spherical Outer Ring	Cylindrical Outer Ring	Spherical Outer Ring	L	L	B	A		
	a	b	c	d	e	f	g	h	i	
 <p>ROUND BORE</p>										
<p>W208PPB2 W208PPB4 W208PPB7 W208PPB23 W209PPB2 W209PPB4 W209PPB11 W210PPB2 W210PPB5 W211PPB2</p>	<p>33811 3017 3017 3811 45 39 45.24 49.23 45.58</p>	<p>80 30.18 80 42.96 30.18 80 30.18 36.53 90 30.18 100</p>	<p>18 30.18 18 33.34 33.34 33.34 22 33.34</p>	<p>45 39 45.24 44.83 45.24 38.11 40 49.23 55.58</p>	<p>85 85 85 85 85 85 85 90 100 100</p>	<p>30.18 30.18 22 22 30.1 30.18 22 30.18 30.18 33.34</p>	<p>44.831 45.24 127 127 38.11 38.11 38.11 40 55.58 55</p>	<p>42.85 42.85 42.85 42.85 42.85 42.85 42.85 44.7 44.7 44.7</p>	<p>40 39 39 39 40 40 44.7 44.7 44.7 44.7</p>	
<p>W207PP3 W208PP5 W208PP6 W208PP20 W208PP8 W208PP11 W208PP18 W209PP3 W210PP4 W211PP3 W211PP5</p>	<p>25 31.8 25.4 31.8 31.8 22.2 22.2 30 28.6 38.1 38.1</p>	<p>45 36.53 36.53 36.5 36.53 36.53 36.53 30.18 30.18 101.6 44.45</p>	<p>18 30.18 30.18 30.18 30.18 30.18 30.18 30.18 30.18 33.34 36.52</p>	<p>28.6 28.6 38.1 22.2 28.6 22.2 28.6 31.8 31.8 38.1 38.1</p>	<p>85.74 85.74 85.74 85.74 85.74 85.74 85.74 85.74 85.74 85.74 85.74</p>	<p>21 30.18 30.18 30.18 30.18 30.18 30.18 30.18 30.2 30.2 30.18 30.2</p>	<p>127 127 127 32.8 30 30 38.9 40.5 140 39.25 40.5 40.5 40.5</p>	<p>42.85 42.85 42.85 42.85 42.85 42.85 42.85 44.7 44.7 44.7 44.7</p>	<p>40 40 39 39 39 39 44.7 44.7 44.7 44.7</p>	
<p>W204KRR2 W205PP13 W205KRR2 W206KRP3 W206KRP6 W207KRP3 W207KRP17 G207KPP3 AH16 W208KRP8 W208PP16</p>	<p>17.65 22.25 22.25 25.43 31.77 31.77 31.78</p>	<p>20.96 25.4 25.4 24 24 25 38</p>	<p>14 15 16 16 17 17 18</p>	<p>17.65 22.25 22.25 25.43 31.77 31.77 31.78</p>	<p>47 52 52 62 72 72 80</p>	<p>20.96 25.4 25.4 24 24 25 38</p>	<p>14 15 16 16 17 17 18</p>	<p>17.65 22.25 22.25 25.43 31.77 31.77 31.78</p>	<p>47 52 52 62 72 72 80</p>	<p>48.5 48.5 48.5 44.7 44.7 44.7 44.7</p>
<p>GZ06KPPB4 GZ06KRRB6</p>	<p>25.43 25.43</p>	<p>24 24</p>	<p>18 18</p>	<p>25.43 25.43</p>	<p>62 62</p>	<p>24 24</p>	<p>18 18</p>	<p>25.43 25.43</p>	<p>24 24</p>	<p>18 18</p>

3.4. Y Bearings Data

3.4.1. Y Ball Bearings with Grub Screw Locking

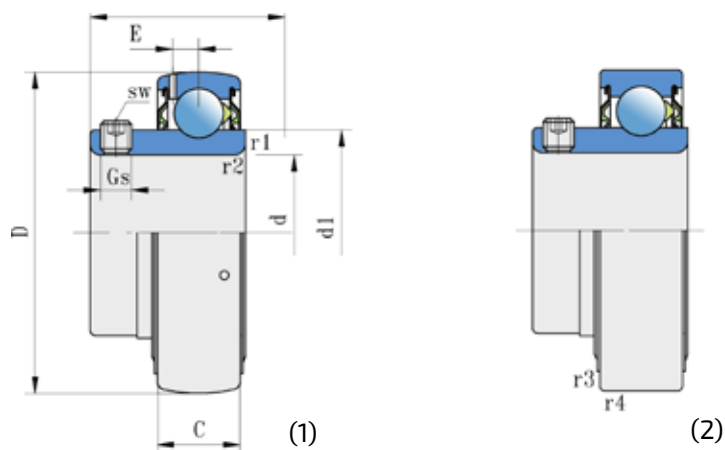

UE...
UE...SH

Shaft		Dimensions (mm)									
d	D	B	C	s	d ₁	E	Gs	sw	a	b	
12 15 17	40	22,1	12	6,2	24,2	3,6	M6X0,75	3	2,06	1,35	
20	47	25,5	14	7,2	28,2	4,3	M6X0,75	3	2,46	1,35	
25	52	27,2	15	7,7	33,6	4,3	M6X0,75	3	2,46	1,35	
30	62	33	18	9,2	39,7	5,6	M6X0,75	3	3,28	1,9	
35	72	33	19	9,7	46,1	5,6	M6X0,75	3	3,28	1,9	
40	80	36	21	10,7	51,8	6,1	M8X1	4	3,28	1,9	
45	85	37	22	11,2	56,6	6,1	M8X1	4	3,28	1,9	
50	90	38,8	22	11,2	62,5	6,4	M10X1	5	3,28	2,7	

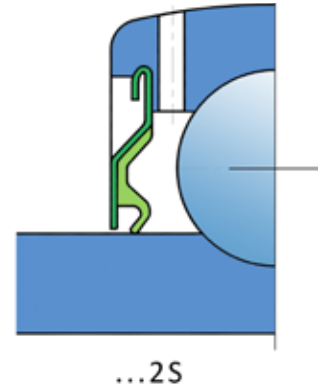

D ₃	r _{1,2}	r _{3,4}	Load ratings (kN)			Mass kg	Designation	
			C	C ₀	Pu		1	2
38,1	0,3	0,6	9,56	4,75	0,200	0,09	UE 203/12 2S	UE 203/12 2S.SH
						0,08	UE 203/15 2S	UE 203/15 2S.SH
						0,07	UE 203 2S	UE 203 2S.SH
44,6	0,6	0,6	12,7	6,55	0,280	0,11	UE 204 2S	UE 204 2S.SH
59,61	0,6	0,6	14	7,8	0,335	0,14	UE 205 2S	UE 205 2S.SH
68,81	0,6	0,6	19,5	11,2	0,475	0,23	UE 206 2S	UE 206 2S.SH
76,81	1	1	25,5	15,3	0,655	0,31	UE 207 2S	UE 207 2S.SH
81,81	1	1,5	30,7	19	0,800	0,43	UE 208 2S	UE 208 2S.SH
81,81	1	1,5	33,2	21,6	0,915	0,48	UE 209 2S	UE 209 2S.SH
86,79	1	1,5	35,1	23,2	0,980	0,54	UE 210 2S	UE 210 2S.SH

3.4.2. Y Ball Bearings with Grub Screw Locking

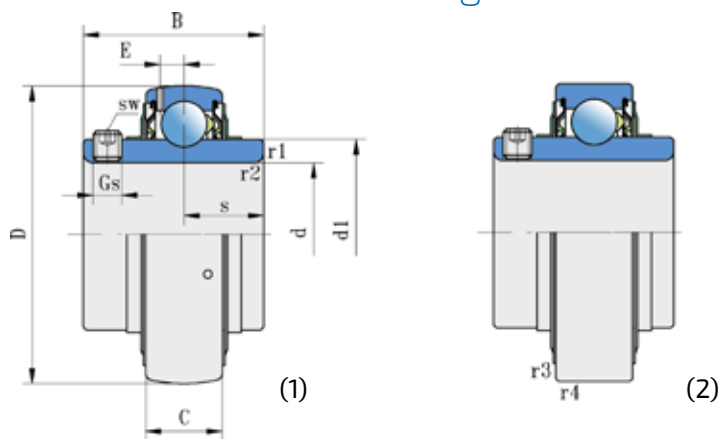

LE...
LE...SH

Shaft	Dimensions (mm)									
d	D	B	C	s	d ₁	E	Gs	sw	a	b
12	40	27,4	12	11,5	24,2	3,6	M6X0,75	3	2,06	1,35
15										
17										
20	47	31	14	12,7	28,2	4,3	M6X0,75	3	2,46	1,35
25	52	34,1	15	14,3	33,6	4,3	M6X0,75	3	2,46	1,35
	62	38	20	15	36,6	5	M6X0,75	3	3,28	1,9
30	62	38,1	18	15,9	39,7	5,1	M6X0,75	3	3,28	1,9
	72	43	23	17	44,6	5,6	M6X0,75	3	3,28	1,9
35	72	42,9	19	17,5	46,1	5,6	M6X0,75	3	3,28	1,9
	80	48	25	19	49,5	5,7	M8X1	4	3,28	1,9
40	80	49,2	21	19	51,8	6,1	M8X1	4	3,28	1,9
	90	52	27	19	56,1	6,1	M10X1	5	3,28	2,7
45	85	49,2	22	19	56,6	6,1	M8X1	4	3,28	1,9
	100	57	29	22	62,1	7,1	M10X1	5	3,28	2,7
50	90	51,6	22	19	62,5	6,4	M10X1	5	3,28	2,7
	110	61	32	22	68,7	7,9	M12X1,5	6	3,28	2,7
55	100	55,6	25	22,2	69,1	7	M10X1	5	3,28	2,7
	120	66	34	25	75,3	8,5	M12X1,5	6	4,06	3,1
60	110	65,1	26	25,4	75,5	7,7	M10X1	5	3,28	2,7
	130	71	36	26	81,8	9	M12X1,5	6	4,06	3,1
65	120	68,3	27	25,4	82,5	7,6	M10X1	5	3,28	2,7
	140	75	39	30	88,3	9,4	M12X1,5	6	4,06	3,1
70	125	69,9	28	30,2	87,1	8,1	M10X1	5	4,06	3,1
	150	78	41	33	94,9	10	M12X1,5	6	4,9	3,1
75	130	73,3	29	27	92,1	8,3	M10X1	5	4,06	3,1
80	140	77,8	30	30,2	97,4	8,2	M10X1	5	4,9	3,1
85	150	81	34	30,2	105	9,3	M12X1,5	6	4,9	3,1
90	160	89	36	35	112,5	10	M12X1,5	6	4,9	3,1
	190	96	48	42	121	14,3	M16X1,5	8	5,69	3,5
100	180	98,4	40	35	112,5	10	M12X1,5	6	5,69	3,1
	215	108	54	40	121	14,3	M16X1,5	10	5,69	3,5
110	240	117	60	46	149	18	M18X1,5	10	6,5	4,5
120	215	73,5	40	28,5	146,4	14	M12X1,5	6	5,69	3,5
	260	126	64	51	164	19,2	M18X1,5	10	-	-

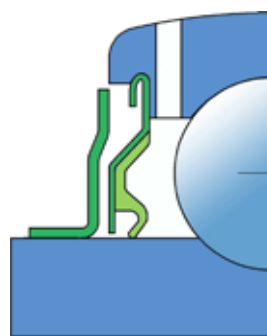

...2F

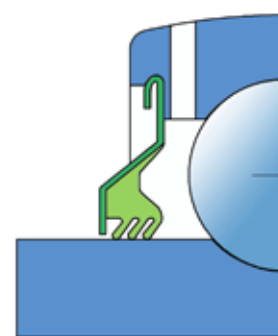

...2T

D ₃	Load ratings (kN)					Mass kg	Designation	
	r _{1,2}	r _{3,4}	C	C ₀	Pu		1	2
38,1	0,3	0,6	9,56	4,75	0,200	0,11	LE 203/12 2F	LE 203/12 2F.SH
						0,10	LE 203/15 2F	LE 203/15 2F.SH
						0,09	LE 203 2F	LE 203 2F.SH
44,6	0,6	0,6	12,7	6,55	0,280	0,14	LE 204 2F	LE 204 2F.SH
49,73	0,6	0,6	14	7,8	0,335	0,17	LE 205 2F	LE 205 2F.SH
59,61	1,1	1,1	22,5	11,6	0,490	0,35	LE 305 2F	LE 305 2F.SH
59,61	0,6	0,6	19,5	11,2	0,475	0,28	LE 206 2F	LE 206 2F.SH
68,81	1,1	1,1	28,1	16	0,670	0,56	LE 306 2F	LE 306 2F.SH
68,81	1	1	25,5	15,3	0,655	0,41	LE 207 2F	LE 207 2F.SH
76,81	1,5	1,5	33,2	19	0,820	0,71	LE 307 2F	LE 307 2F.SH
76,81	1	1	30,7	19	0,800	0,55	LE 208 2F	LE 208 2F.SH
86,79	1,5	1,5	41	24	1,020	0,96	LE 308 2F	LE 308 2F.SH
81,81	1	1,5	33,2	21,6	0,915	0,60	LE 209 2F	LE 209 2F.SH
96,8	1,5	1,5	52,7	31,5	1,340	1,28	LE 309 2F	LE 309 2F.SH
86,79	1	1,5	35,1	23,2	0,980	0,69	LE 210 2F	LE 210 2F.SH
106,81	2	2	61,8	38	1,600	1,65	LE 310 2F	LE 310 2F.SH
96,8	1	2	43,6	29	1,25	0,94	LE 211 2F	LE 211 2F.SH
115,21	2	2	71,5	45	1,90	2,07	LE 311 2F	LE 311 2F.SH
106,81	1,5	2	52,7	36	1,53	1,30	LE 212 2F	LE 212 2F.SH
125,22	2,1	2,1	81,0	52	2,20	2,60	LE 312 2F	LE 312 2F.SH
115,21	1,5	2	57,2	40	1,70	1,70	LE 213 2F	LE 213 2F.SH
135,23	2,1	2,1	92,3	60	2,50	3,25	LE 313 2F	LE 313 2F.SH
120,22	1,5	2	62,4	44	1,86	1,90	LE 214 2F	LE 214 2F.SH
145,24	2,1	2,1	104	68	2,75	3,89	LE 314 2F	LE 314 2F.SH
125,22	1,5	2	66,3	49	2,04	2,10	LE 215 2F	LE 215 2F.SH
135,23	2	2,5	72,8	53	2,16	2,80	LE 216 2F	LE 216 2F.SH
145,24	2	2,5	83,2	62	2,50	3,30	LE 217 2F	LE 217 2F.SH
155,22	2	2,5	95,6	72	2,70	4,10	LE 218 2F	LE 218 2F.SH
183,64	3	3	151	108	3,80	7,87	LE 318 2F	LE 318 2F.SH
173,66	2	2,5	124	93	3,35	5,65	LE 220 2F	LE 220 2F.SH
208,6	3	3	174	140	4,75	11,2	LE 320 2F	LE 320 2F.SH
232	3	3	203	180	5,70	15,1	LE 322 2F	LE 322 2F.SH
208,6	2	2,5	155	113	3,90	6,20	LE 224 2F	LE 224 2F.SH
-	3	3	208	186	5,70	19	LE 324 2F	LE 324 2F.SH

3.4.3. Y Ball Bearings with Eccentric Locking Collar

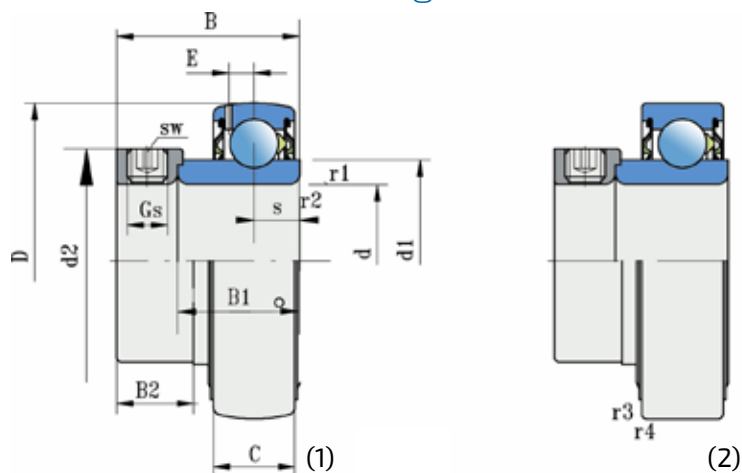

UY...
UY...SH

Shaft		Dimensions (mm)												
d	D	B	C	s	d ₁	B ₁	d ₂	B ₂	E	G _s	sw	a	b	
12 15 17	40	28,6	12	6,5	24,2	19,1	28,6	13,5	3,6	M6X0,75	3	2,06	1,35	
20	47	31	14	7,5	28,2	21,5	33	13,5	4,3	M6X0,75	3	2,46	1,35	
25	52	31	15	7,5	33,6	21,5	37,4	13,5	4,3	M6X0,75	3	2,46	1,35	
30	62	35,7	18	9	39,7	23,8	44,2	16	5,1	M8X1	4	3,28	1,9	
35	72	38,9	19	9,5	46,1	25,4	51,2	17,5	5,6	M10X1	5	3,28	1,9	
40	80	43,7	21	11	51,8	30,2	58,2	18,3	6,1	M10X1	5	3,28	1,9	
45	85	43,7	22	11	56,6	30,2	63,6	18,3	6,1	M10X1	5	3,28	1,9	
50	90	43,7	22	11	62,5	30,2	67,6	18,3	6,4	M10X1	5	3,28	2,7	
55	100	48,4	25	12,5	69,1	32,5	76,2	20,6	7	M10X1	5	3,28	2,7	
60	110	53,3	26	13,5	75,5	37,5	84	22,3	7,7	M10X1	5	3,28	2,7	

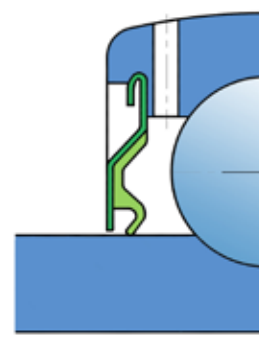

...2S

D ₃	r _{1,2}	r _{3,4}	Load ratings (kN)			Mass kg	Designation	
			C	C ₀	P _u		1	2
38,1	0,3	0,6	9,56	4,75	0,200	0,09	UY 203/12 2S	UY 203/12 2S.SH
						0,08	UY 203/15 2S	UY 203/15 2S.SH
						0,07	UY 203 2S	UY 203 2S.SH
44,6	0,6	0,6	12,7	6,55	0,280	0,11	UY 204 2S	UY 204 2S.SH
49,73	0,6	0,6	14	7,8	0,335	0,14	UY 205 2S	UY 205 2S.SH
59,61	0,6	0,6	19,5	11,2	0,475	0,23	UY 206 2S	UY 206 2S.SH
68,81	1	1	25,5	15,3	0,655	0,31	UY 207 2S	UY 207 2S.SH
76,81	1	1,5	30,7	19	0,800	0,43	UY 208 2S	UY 208 2S.SH
81,81	1	1,5	33,2	21,6	0,915	0,48	UY 209 2S	UY 209 2S.SH
86,79	1	1,5	35,1	23,2	0,980	0,54	UY 210 2S	UY 210 2S.SH
96,8	1	2	43,6	29	1,25	0,98	UY 211 2S	UY 211 2S.SH
106,81	1,5	2	52,7	36	1,53	1,3	UY 212 2S	UY 212 2S.SH

3.4.4. Y Ball Bearings with Eccentric Locking Collar

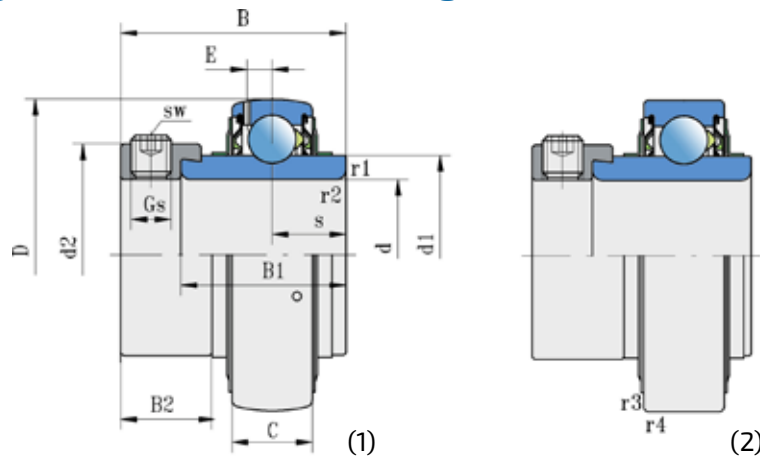

LY...
LY...SH

Shaft		Dimensions (mm)												
d	D	B	C	s	d ₁	B ₁	d ₂	B ₂	E	G _s	sw	a	b	
12	40	37,3	12	13,9	24,2	27,8	28,6	13,5	3,6	M6X0,75	3	2,06	1,35	
15														
17														
20	47	43,7	14	17,1	28,2	34,1	33	13,5	4,3	M6X0,75	3	2,46	1,35	
25	52	44,4	15	17,5	33,6	34,8	37,4	13,5	4,3	M6X0,75	3	2,46	1,35	
	62	46,8	20	16,7	36,6	34,9	42,8	15,9	5	M8X1	4	3,28	1,9	
30	62	48,4	18	18,3	39,7	36,5	44,2	16	5,1	M8X1	4	3,28	1,9	
	72	50	23	17,5	44,6	36,5	50	17,5	5,6	M8X1	4	3,28	1,9	
35	72	51,1	19	18,8	46,1	37,6	51,2	17,5	5,6	M10X1	5	3,28	1,9	
	80	51,6	25	18,3	49,5	38,1	55	17,5	5,7	M8X1	4	3,28	1,9	
40	80	56,3	22	21,4	56,6	42,8	63,6	18,3	6,1	M10X1	5	3,28	1,9	
	90	57,1	29	19,8	62,1	42,9	70	20,6	7,1	M10X1	5	3,28	2,7	
45	85	56,3	22	21,4	56,6	42,8	63,6	18,3	6,1	M10X1	5	3,28	1,9	
	100	58,7	29	19,8	62,1	42,9	70	20,6	7,1	M10X1	5	3,28	2,7	
50	90	62,7	22	24,6	62,5	49,2	67,6	18,3	6,4	M10X1	5	3,28	2,7	
	110	66,6	32	24,6	68,7	49,2	76,2	22,2	7,9	M10X1	5	3,28	2,7	
55	100	71,4	25	27,8	69,1	55,6	76,2	20,6	7	M10X1	5	3,28	2,7	
	120	73	34	27,8	75,3	55,6	83	22,2	8,5	M10X1	5	4,06	3,1	
60	110	77,8	26	31	75,5	62	84	22,3	7,7	M10X1	5	3,28	2,7	
	130	79,4	36	30,9	81,8	61,9	89	23,9	9,0	M10X1	5	4,06	3,1	
65	120	85,7	27	34,1	82,5	68,2	86	24	7,6	M10X1	5	4,06	3,1	
	140	85,7	39	32,6	88,3	65,1	97	27	9,4	M12X1,5	6	4,9	3,1	
70	125	85,7	28	34,1	87,1	68,2	92,9	23,8	8,1	M10X1	5	4,06	3,1	
	150	92,1	41	34,2	94,9	68,3	102	30,2	10	M12X1,5	6	4,9	3,1	
75	130	92,1	29	37,3	92,1	74,6	101,7	24	8,3	M10X1	5	4,06	3,1	
80	140	100	30	40,4	97,4	80,8	110	26,2	8,2	M12X1,5	6	4,9	3,1	
90	160	106,4	36	43,6	112,5	88,2	123,7	25,2	10	M12X1,5	6	4,9	3,1	
	190	115,9	48	43,6	121	87,3	133	38,5	14,3	M20X1,5		5,69	3,5	
100	180	75	40	25,5	124,8	57,5	130	25,5	12	M12X1,5	6	5,69	3,1	
	215	128,6	54	50	135	100	146	38,5	16,7	M20X1,5		5,69	3,5	
110	240	141,3	60	49,2	149	106,4	168	44,8	18	M20X1,5		6,5	4,5	
120	215	81	40	28,5	146,4	63,5	150	25,5	14	M12X1,5	6	5,69	3,5	

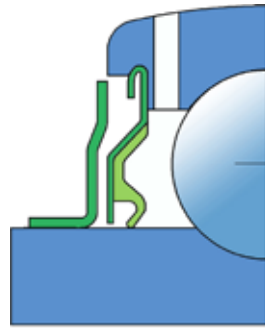

...2F

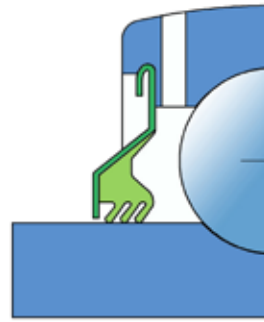

...2T

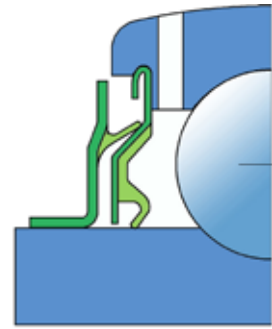

...2B

D ₃	Load ratings (kN)					Mass kg	Designation	
	r _{1,2}	r _{3,4}	C	C ₀	Pu		1	2
38,1	0,3	0,6	9,56	4,75	0,200	0,162 0,143 0,128	LY 203/12 2F LY 203/15 2F LY 203 2F	LY 203/12 2F.SH LY 203/15 2F.SH LY 203 2F.SH
44,6	0,6	0,6	12,7	6,55	0,280	0,19	LY 204 2F	LY 204 2F.SH
49,73	0,6	0,6	14	7,8	0,335	0,23	LY 205 2F	LY 205 2F.SH
59,61	1,1	1,1	22,5	11,6	0,490	0,43	LY 305 2F	LY 305 2F.SH
59,61	0,6	0,6	19,5	11,2	0,475	0,37	LY 206 2F	LY 206 2F.SH
68,81	1,1	1,1	28,1	16	0,670	0,68	LY 306 2F	LY 306 2F.SH
68,81	1	1	25,5	15,3	0,655	0,57	LY 207 2F	LY 207 2F.SH
76,81	1,5	1,5	33,2	19	0,820	0,80	LY 307 2F	LY 307 2F.SH
76,81	1	1,5	30,7	19	0,800	0,80	LY 208 2F	LY 208 2F.SH
86,79	1,5	1,5	41	24	1,020	1,08	LY 308 2F	LY 308 2F.SH
81,81	1	1,5	33,2	21,6	0,915	0,76	LY 209 2F	LY 209 2F.SH
96,8	1,5	1,5	52,7	31,5	1,340	1,44	LY 309 2F	LY 309 2F.SH
86,79	1	1,5	35,1	23,2	0,980	0,91	LY 210 2F	LY 210 2F.SH
106,81	2	2	61,8	38	1,600	1,86	LY 310 2F	LY 310 2F.SH
96,8	1	2	43,6	29	1,25	1,20	LY 211 2F	LY 211 2F.SH
115,21	2	2	71,5	45	1,90	2,34	LY 311 2F	LY 311 2F.SH
106,81	1,5	2	52,7	36	1,53	1,67	LY 212 2F	LY 212 2F.SH
125,22	2,1	2,1	81,9	52	2,20	2,95	LY 312 2F	LY 312 2F.SH
115,21	1,5	2	57,2	40	1,70	2,30	LY 213 2F	LY 213 2F.SH
135,23	2,1	2,1	92,3	60	2,50	3,67	LY 313 2F	LY 313 2F.SH
120,22	1,5	2	62,4	44	1,86	2,50	LY 214 2F	LY 214 2F.SH
145,24	2,1	2,1	104	68	2,75	4,40	LY 314 2F	LY 314 2F.SH
125,22	1,5	2	66,3	49	2,04	2,90	LY 215 2F	LY 215 2F.SH
135,23	2	2,5	72,8	53	2,16	3,54	LY 216 2F	LY 216 2F.SH
155,22	2	2,5	95,6	72	2,70	5,11	LY 218 2F	LY 218 2F.SH
183,64	3	3	151	108	3,80	9,10	LY 318 2F	LY 318 2F.SH
173,66	2	2,5	124	93	3,35	4,35	LY 220 2F	LY 220 2F.SH
208,6	3	3	174	140	4,75	12,6	LY 320 2F	LY 320 2F.SH
232	3	3	203	180	5,70	17,2	LY 222 2F	LY 222 2F.SH
208,6	2	2,5	155	113	3,90	6,70	LY 224 2F	LY 224 2F.SH

3.4.5. Y Ball Bearings with Integral Adapter Sleeve

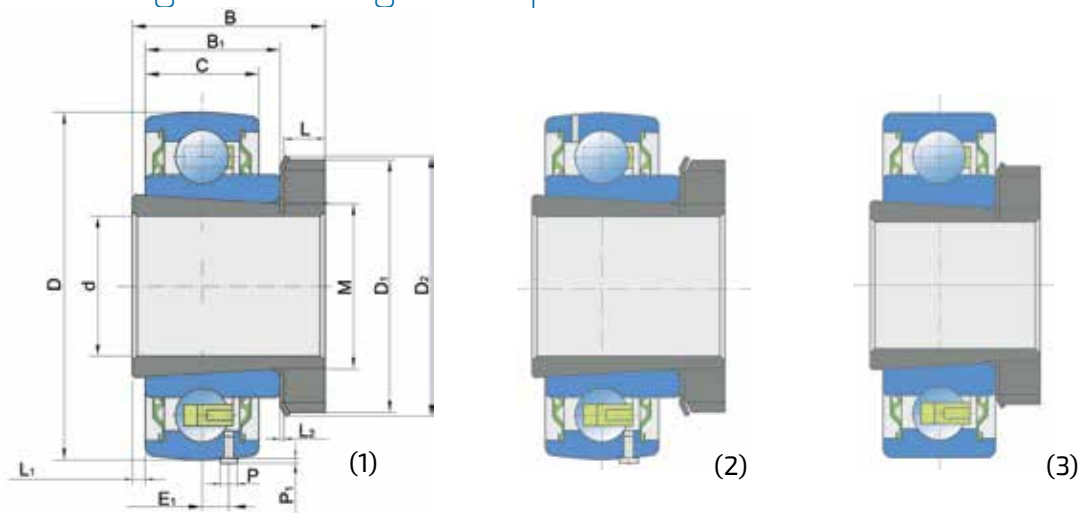

UH...

Shaft		Dimensions (mm)										
d	D	D ₁	D ₂	B	B ₁	C	L	L ₁	L ₂	E	E ₁	M
20	52	38	42,3	29	18	16	7	1	1,25		4,3	25x1,5
25	62	45	49	32	20	18	7	1	1,25		5	30x1,5
30	72	52	57	35	22	19	8	1	1,25		5,7	35x1,5
35	80	58	62	36	23	21	9	1	1,25		6,5	35x1,5
40	85	65	69	39	23	21	10	1	1,25		6,5	40x1,5
30	85	52	57	35	23	23	8	1	1,25			35x1,5
35	85	58	62	36	23	23	9	1	1,25			40x1,5
40	85	65	69	39	23	23	10	1	1,25			45x1,5
40	85	65	69	39	23	21	10	1	1,25	6,5	6,5	45x1,5
50	100	75	81	45	25	25	11	1	1,25	7	7	50x2
70	150	105	112	70	45	39	15	1	1,75	12	12	80x2

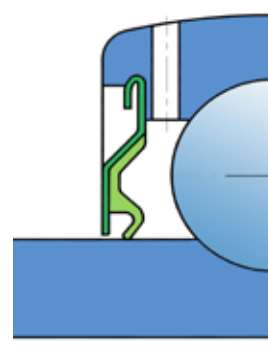

...2S

P	P ₁	Load ratings (kN)			Mass kg	Designation	Fig.
		C	C ₀	P _u			
3	2	14	7,8	0,335	0,196	UH 205/20 2S.H.T	1
3	2	19,5	11,2	0,475	0,337	UH 206/25 2S.H.T	1
3	2	25,5	15,3	0,655	0,467	UH 207/30 2S.H.T	1
3	2	30,7	19	0,800	0,600	UH 208/35 2S.H.T	1
3	2	33,2	21,6	0,915	0,643	UH 209/40 2S.H.T	1
		33,2	21,6	0,915	0,737	UH 209/30 2S.SH	3
		33,2	21,6	0,915	0,700	UH 209/35 2S.SH	3
		33,2	21,6	0,915	0,727	UH 209/40 2S.SH	3
3	2	33,2	21,6	0,915	0,643	UH 209/40 2S.T	2
3	2	43,6	29	1,25	1,002	UH 211/50 2S.T	2
5	2,8	85	65	2,5	3,87	UH 211/70 2S.T	2

3.4.6. Y Ball Bearings with Standard Inner Ring

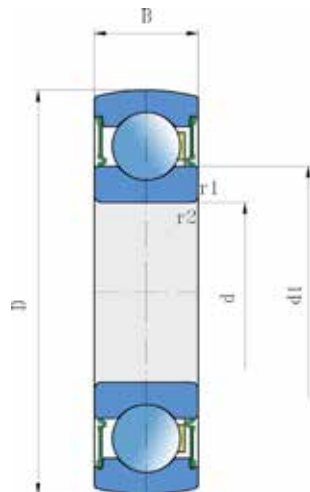

172...

Shaft d	Dimensions (mm)			Load ratings (kN)			Mass kg	Designation	
	D	B	d ₁	r _{1,2}	C	C ₀			P _u
15	35	11	21,5	0,6	7,80	3,75	0,16	0,04	1726202 2RS1
	47		26,5						
20	47	14	28,2	1	12,7	6,55	0,28	0,10	1726204 2RS1
	52		33,6						
25	62	17	36,6	1,1	22,5	11,6	0,49	0,20	1726305 2RS1
	72		44,6						
30	72	19	44,6	1,1	28,1	16	0,67	0,30	1726306 2RS1
	80		49,5						
35	80	23	56,1	1,5	41	24	1,02	0,55	1726308 2RS1
	90		56,1						
40	90	27	68,7	2	61,8	38	1,60	0,95	1726310 2RS1
	100		62,1						
45	110	31	75,5	1,5	52	36	1,40	0,75	1726212 2RS1
	120		82,5						
50	120	31	75,5	1,5	52	36	1,40	0,75	1726212 2RS1
55	120	31	75,5	1,5	52	36	1,40	0,75	1726212 2RS1
60	120	31	75,5	1,5	52	36	1,40	0,75	1726212 2RS1
65	120	31	75,5	1,5	52	36	1,40	0,75	1726212 2RS1

3.4.7. Y Ball Bearings with Extended Standard Inner Ring

3.4.8. Y Ball Bearings with Drive Slot in Inner Ring

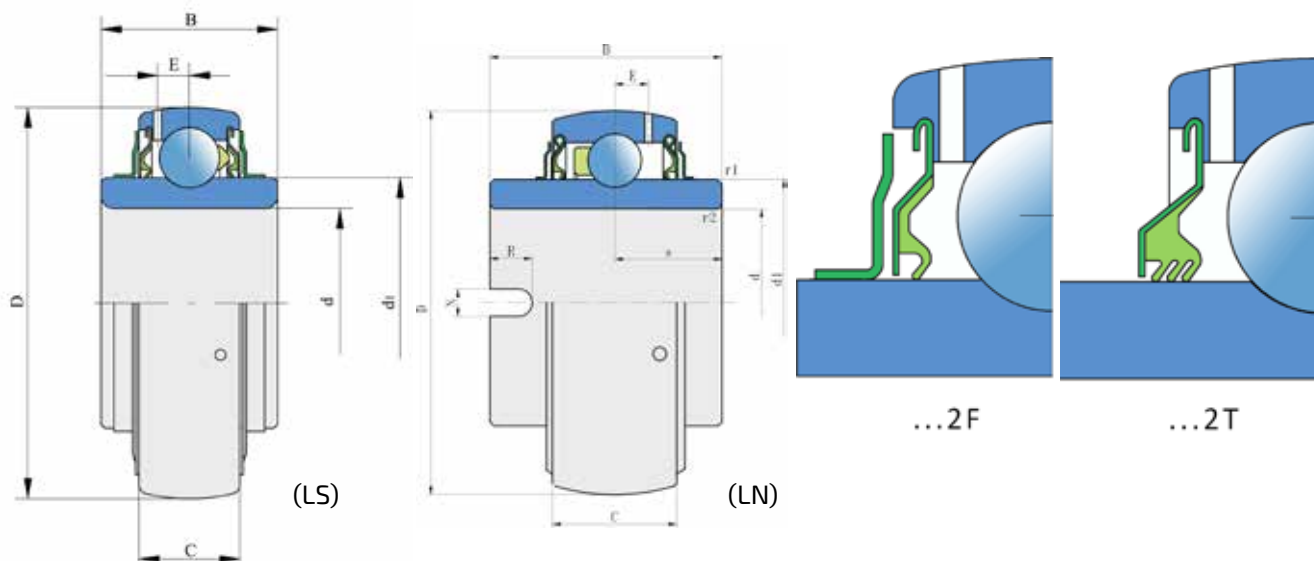

LS...

Shaft d	Dimensions (mm)					Load rating (kN)			Mass kg	Designations
	D	B	C	d ₁	E	C	C ₀	P _u		
25	52	24	15	33,6	4,3	14	7,8	0,335	0,14	LS 205 2F
30	62	28	18	39,7	5,1	19,5	11,2	0,475	0,23	LS 206 2F
35	72	30,5	19	46,1	5,6	25,5	15,3	0,655	0,31	LS 207 2F
40	80	33,9	21	51,8	6,1	30,7	19	0,800	0,43	LS 208 2F
45	85	35	22	56,6	6,1	33,2	21,6	0,915	0,53	LS 209 2F
50	90	37	22	62,5	6,4	35,1	23,2	0,980	0,6	LS 210 2F
55	100	40	25	69,1	7	43,6	29	1,25	0,79	LS 211 2F

LN...

20	47	34,1	14	28,2	4,3	12,7	6,55	0,280	0,16	LN 204 2F
30	62	36,5	18	39,7	5,1	19,5	11,2	0,475	0,30	LN 206 2F
35	72	37,7	19	46,1	5,6	25,5	15,3	0,655	0,49	LN 207 2F

3.4.9. Y Ball Bearings with Standard Inner Ring

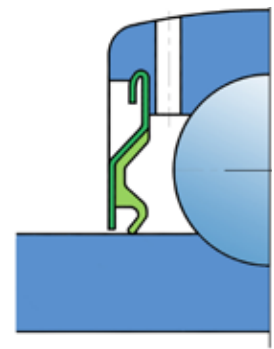
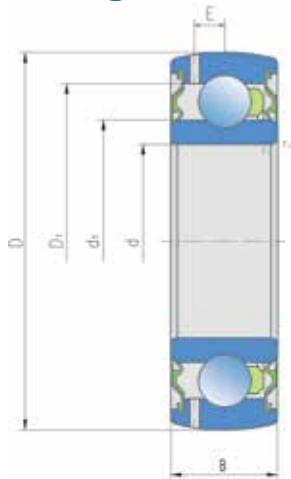

...2S

US...

Shaft	Dimensions (mm)						Load rating (kN)			Mass kg	Designations
	d	D	B	d ₁	D ₁	E	r _{1,2}	C ₀	P _u		
17	40	12	24,2	32,6	3,6	0,6	4,75	0,140	7,35	0,064	US 203 2S
	47	14	26,5	37,6	4,3	0,7	6,55	0,275	13,5	0,14	US 303 2S
20	47	14	28,2	38,6	4,3	1	6,6	0,196	12,8	0,094	US 204 2S
25	52	15	33,6	44	4,3	1	7,80	0,232	14	0,116	US 205 2S
	62	17	36,6	50,9	5,6	1,1	11,6	0,49	22,5	0,20	US 305 2S
30	62	16	39,7	51,6	5,1	1	11,3	0,335	19,5	0,18	US 206 2S
	72	19	44,6	59,2	6,1	1,1	16	0,67	28,1	0,30	US 306 2S
35	72	17	46,1	60,5	5,6	1,1	15,3	0,455	25,5	0,28	US 207 2S
	80	21	49,5	66,1	7	1,5	19	0,82	33,2	0,40	US 307 2S
40	80	18	52,0	67,3	6,1	1,1	19,8	0,560	32,5	0,37	US 208 2S
	90	23	56,1	74,7	7,6	1,5	24	1,02	41	0,55	US 308 2S
45	85	19	56,6	72,6	6,1	1,1	20,4	0,640	32,5	0,40	US 209 2S
	100	25	62,1	83,7	7,7	1,5	31,5	1,34	52,7	0,73	US 309 2S
50	90	20	62,5	78,2	6,4	1,1	23,2	0,695	35	0,45	US 210 2S
	110	27	68,7	92,6	7,7	2	38	1,6	61,8	0,95	US 310 2S
55	100	21	69,1	85,9	7	1,5	29,0	0,865	43,5	0,60	US 211 2S
60	110	22	75,5	95	7,7	1,5	36,0	1,060	52	0,77	US 212 2S
65	120	23	82,5	102,46	7,6	1,5	40	1,73	57	0,94	US 213 2S

3.4.10. Y Ball Bearings with Tapered Bore Y Ball Bearings whit Adapter Sleeve

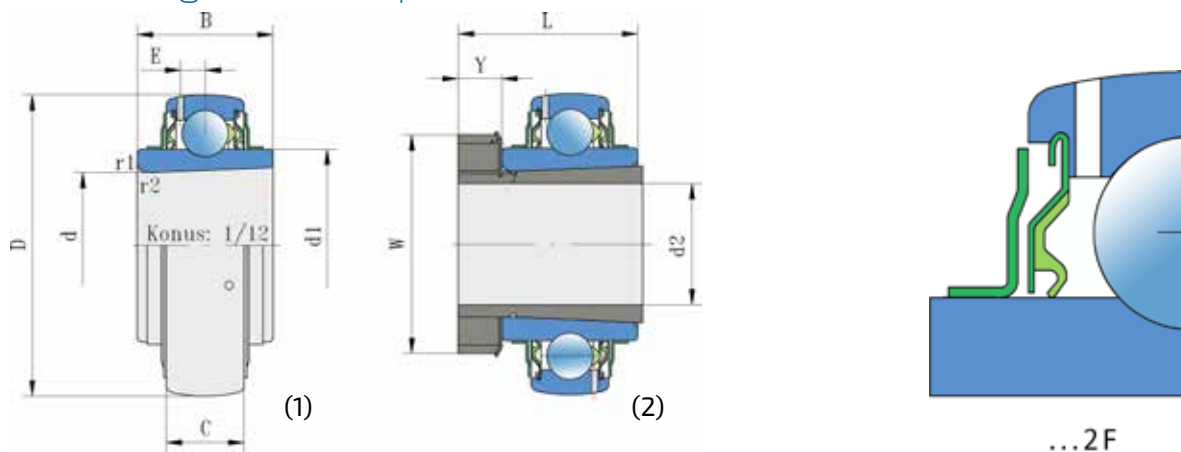

LK...
LK...+H...

Shaft		Dimensions (mm)						Load ratings (kN)			Mass	Designation		
d_2	d	D	L	B	C	d_1	W	Y	E	C	C_0	P_u	kg	1, 2
20	25	52		23	15	33,6			4,3	14	7,8	0,232	0,13	LK 205 2F
			35				38	8						0,22
25	30	62		26	18	39,7			5,1	19,5	11,3	0,335	0,22	LK 206 2F
			38				45	8						0,33
30	35	72		27	19	46,1			5,6	25,5	15,3	0,445	0,29	LK 207 2F
			43				52	9						0,47
35	40	80		29	21	52			6,1	32,5	19,8	0,560	0,41	LK 208 2F
			46				58	10						0,63
40	45	85		30	22	56,6			6,1	32,5	20,4	0,640	0,47	LK 209 2F
			50				65	11						0,73
45	50	90		31	22	62,5			6,4	35	23,2	0,695	0,51	LK 210 2F
			55				70	12						0,86
50	55	100		33	25	69,1			7	43,5	29	0,865	0,75	LK 211 2F
			59				75	12						1,10
55	60	110		36	26	75,5			7,7	52	36	1,060	1,05	LK 212 2F
			62				80	13						1,40
60	65	120		38	27	82,5			7,6	57	40	1,180	1,30	LK 213 2F
			65				98	14						1,70
65	75	130		41	29	92,1			8,3	62	44,5	1,44	1,54	LK 215 2F
			73				98	15						2,59
70	80	140		44	30	97,4			8,2	72	54	1,53	1,99	LK 216 2F
			78				105	17						3,27
75	85	150		46	34	105			8,2	85	65	1,72	2,47	LK 217 2F
			82				110	18						3,92
80	90	160		49	36	112			10	102	79	1,96	2,99	LK 218 2F
			86				120	18						4,68

3.4.11. Y Ball Bearings with Tapered Bore

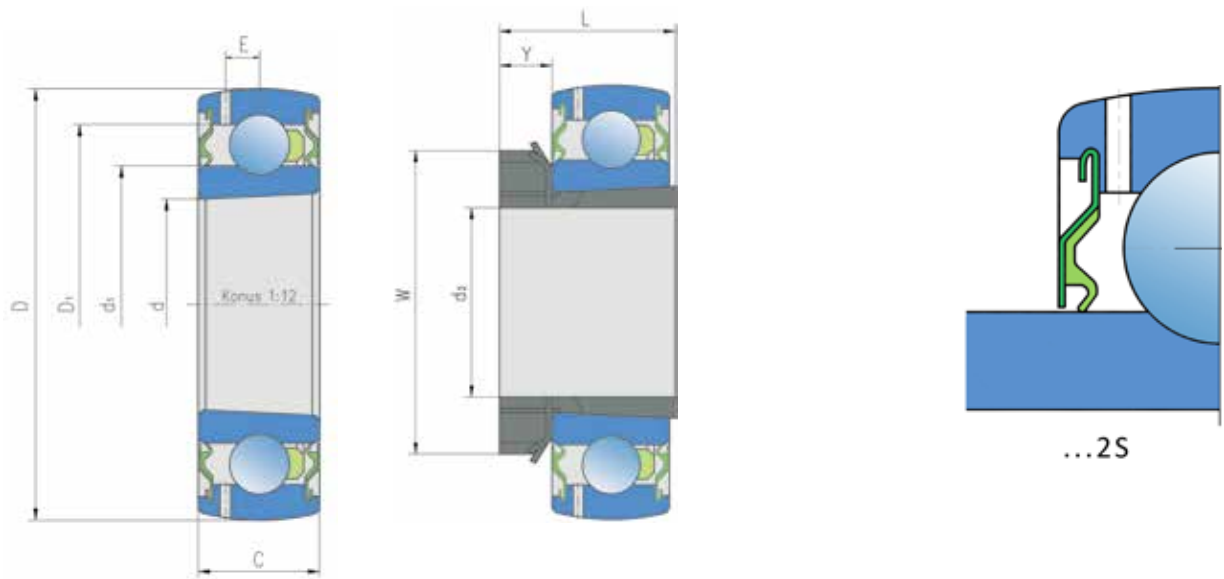

UK...

Shaft	Dimensions (mm)							Load rating (kN)				Mass kg	Designation		
	d_2	d	D	L	B	C	d_1	D_1	W	Y	E			C	C_0
20	25	52		15	15	33,6	44			4,3	14,0	7,80	0,232	0,14	UK 205 2S
			26						38	8					UK 205 2S+H 205
25	30	62		16	16	39,7	51,6			5,1	19,5	11,3	0,335	0,18	UK 206 2S
			27						45	8					UK 206 2S+H 206
30	35	72		17	17	46,1	60,5			5,6	25,5	15,3	0,445	0,28	UK 207 2S
			29						52	9					UK 207 2S+H 207
35	40	80		18	18	52	67,3			6,1	32,5	19,8	0,560	0,36	UK 208 2S
			31						58	10					UK 208 2S+H 208
40	45	85		19	19	56,6	72,6			6,1	32,5	20,4	0,640	0,39	UK 209 2S
			33						65	11					UK 209 2S+H 209
45	50	90		20	20	62,5	78,2			6,4	35,0	23,2	0,695	0,44	UK 210 2S
			55						70	12					UK 210 2S+H 210
50	55	100		21	21	69,1	85,9			7	43,5	29,0	0,865	0,59	UK 211 2S
			59						75	12					UK 211 2S+H 211
55	60	110		22	22	75,5	95			7,7	52,0	36,0	1,060	0,75	UK 212 2S
			62						80	13					UK 212 2S+H 212

3.5. Angular Contact Ball Bearing - Double Row

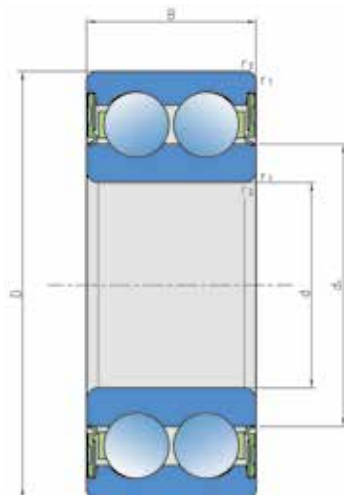

32...
33...

Shaft d	Dimensions (mm)			Load ratings (kN)				Mass kg	Designation
	D	B	d ₁	r _{1,2}	C	C ₀	P _u		
20	47	20,6	27,7	1	20	12	0,51	0,16	3204 B.2RS1
25	52	20,6	32,7	1	21,6	14,3	0,6	0,18	3205 B.2RS1
30	62	23,8	38,7	1	30	20,4	0,87	0,29	3206 B.2RS1
35	80	24,9	44,6	1,5	52	35,5	1,5	0,71	3307 B.2RS1

3.6. Y Bearing Units Data

3.6.1. Y Bearing Plummer Block Units - Grey Cast Iron Housing "S"

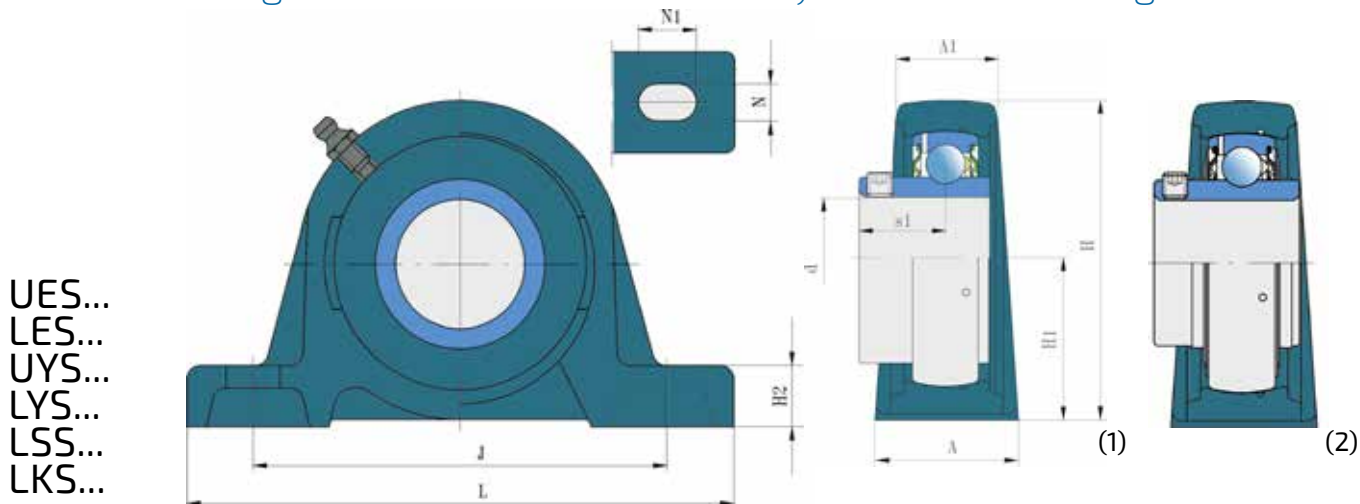

UES...
LES...
UYS...
LYS...
LSS...
LKS...

Shaft d	Dimensions (mm)											fig.	Mass kg	Designation
	A	A ₁	H	H ₁	H ₂	J _{min.}	J _{max.}	L	N	N ₁	s ₁			
17	32	18	56,2	30,2	14	88	106	127	11,5	20,5	15,9	1	0,48	UES 203 2S
												2	0,50	LES 203 2F
												3	0,52	UYS 203 2S
												4	0,54	LYS 203 2F
20	34	23	63,8	33,3	14	89	104,5	127	13	20,7	18,3	1	0,55	UES 204 2S
												2	0,57	LES 204 2F
												3	0,59	UYS 204 2S
												4	0,62	LYS 204 2F
												6	0,77	LKS 205 2F + H2305
												6	0,77	LKS 205 2F + H2305
25	38	24	69,5	36,5	16	94	111	140	13	21,5	19,5	1	0,70	UES 205 2S
												2	0,73	LES 205 2F
												3	0,73	UYS 205 2S
												4	0,78	LYS 205 2F
												5	0,70	LSS 205 2F
												6	1,15	LKS 206 2F + H2306
30	42	27	81,4	42,9	16	111	125	165	17	24	21	1	1,06	UES 206 2S
												2	1,12	LES 206 2F
												3	1,12	UYS 206 2S
												4	1,19	LYS 206 2F
												5	1,06	LSS 206 2F
												6	1,55	LKS 207 2F + H2307
35	46	28	92,1	47,6	17	122	136	167	17	24	23,3	1	1,46	UES 207 2S
												2	1,53	LES 207 2F
												3	1,58	UYS 207 2S
												4	32,3	LYS 207 2F
												5	1,47	LSS 207 2F
												6	1,90	LKS 208 2F + H2308
40	49	31	98,2	49,2	18	128	145	184	17	25,5	25,3	1	1,85	UES 208 2S
												2	1,96	LES 208 2F
												3	1,99	UYS 208 2S
												4	2,08	LYS 208 2F
												5	1,88	LSS 208 2F
												6	2,35	LKS 209 2F + H2309
52	36	107	54	20	136	151	190	17	23,5	28,5	6	2,35	LKS 209 2F + H2309	

* All bearing units are available from Ductile Cast Iron.

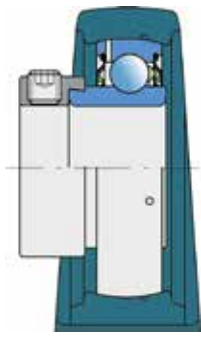

(3)

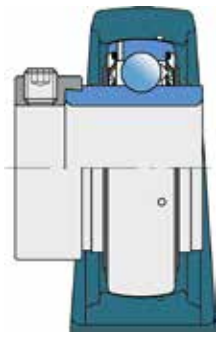

(4)



(5)

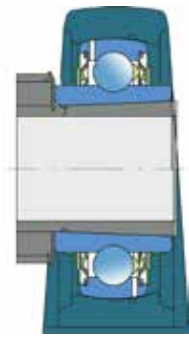

(6)

Shaft d	Dimensions (mm)											fig.	Mass kg	Designation
	A	A ₁	H	H ₁	H ₂	J _{min.}	J _{max.}	L	N	N ₁	s ₁			
45	52	36	107	54	20	136	151	190	17	23,5	25,8	1	2,23	UES 209 2S
											30,2	2	2,34	LES 209 2F
											32,7	3	2,34	UYS 209 2S
											34,9	4	2,46	LYS 209 2F
											17,5	5	2,25	LSS 209 2F
											30,5	6	2,85	LKS 210 2F + H2310
50	58	38	113,2	57,2	22	151	164	206	20	26,5	27,6	1	2,59	UES 210 2S
											32,6	2	2,74	LES 210 2F
											32,7	3	2,73	UYS 210 2S
											38,1	4	2,92	LYS 210 2F
											20	5	2,65	LSS 210 2F
											32,5	6	3,75	LKS 211 2F + H2311
55	60	40	125,5	63,5	24	163	180	219	20	27,5	33,4	2	3,62	LES 211 2F
											35,9	3	3,59	UYS 211 2S
											43,6	4	3,80	LYS 211 2F
											21,2	5	3,59	LSS 211 2F
											34,3	6	4,55	LKS 212 2F + H2312
											39,7	2	4,62	LES 212 2F
60	65	47	136,8	69,8	26,5	179	198	241	20	29,5	39,7	2	4,62	LES 212 2F
											40,3	3	4,19	UYS 212 2S
											46,8	4	4,82	LYS 212 2F
											35,8	6	5,70	LKS 213 2F + H2313
											42,9	2	6,02	LES 213 2F
											51,6	4	6,55	LYS 213 2F
65	74	54	165	82,5	28	209	225	275	25	33	38,8	6	7,55	LKS 215 2F + H2315
											39,7	2	6,60	LES 214 2F
											51,6	4	7,10	LYS 214 2F
70	78	50	175	88,9	30	222	242	292	25	35	41,5	6	9,50	LKS 216 2F + H2316
											46,3	2	7,80	LES 215 2F
											54,8	4	8,40	LYS 215 2F
80	88	54	200	101,6	33	254	270	327	27	35	47,6	2	9,20	LES 216 2F
											59,6	4	10,0	LYS 216 2F
											47	6	13,7	LKS 218 2F + H2318
90	88	54	200	101,6	33	254	270	327	27	35	54	2	13,7	LES 218 2F
											62,8	4	14,6	LYS 218 2F
100	95	57	225	115	38	286	330	380	26	48	63,4	2	17,8	LES 220 2F
											49,5	4	17,4	LYS 220 2F

3.6.2. Y Bearing Plummer Block Units - Grey Cast Iron Housing "V"

UEV...
LEV...
UYV...
LYV...
LSV...
LKV...

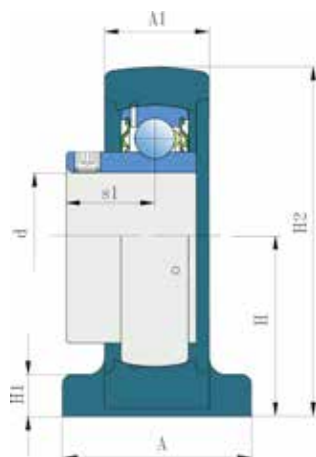
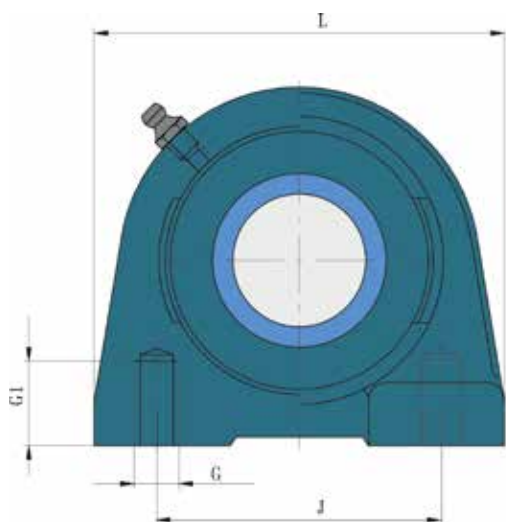

(1)

(2)

Shaft d	Dimensions (mm)							H ₂	A ₁	s ₁	fig.	Mass kg	Designation
	L	A	J	H	G	G ₁	H ₁						
20	76	38	52	30,2	M10	12	8	62	24	18,3	1	0,52	UEV 204 2S
										18,3	2	0,54	LEV 204 2F
										23,5	3	0,56	UYV 204 2S
										26,6	4	0,59	LYV 204 2F
										20	6	0,74	LKV 205 2F + H2305
										84	38	56	36,5
25	84	38	56	36,5	M10	15	10	72	25	19,5	1	0,65	UEV 205 2S
										19,8	2	0,68	LEV 205 2F
										23,5	3	0,68	UYV 205 2S
										26,9	4	0,73	LYV 205 2F
										12	5	0,65	LSV 205 2F
										94	48	66	42,9
30	94	48	66	42,9	M14	18	10	84	28,5	21	1	0,97	UEV 206 2S
										22,2	2	1,03	LEV 206 2F
										26,7	3	1,03	UYV 206 2S
										30,1	4	1,10	LYV 206 2F
										14	5	0,97	LSV 206 2F
										110	48	80	47,6
35	110	48	80	47,6	M14	20	12	95	30,5	23,3	1	1,37	UEV 207 2S
										25,5	2	1,44	LEV 207 2F
										29,4	3	1,49	UYV 207 2S
										32,3	4	1,57	LYV 207 2F
										15,2	5	1,38	LSV 207 2F
										116	54	84	49,2

* All bearing units are available from Ductile Cast Iron.

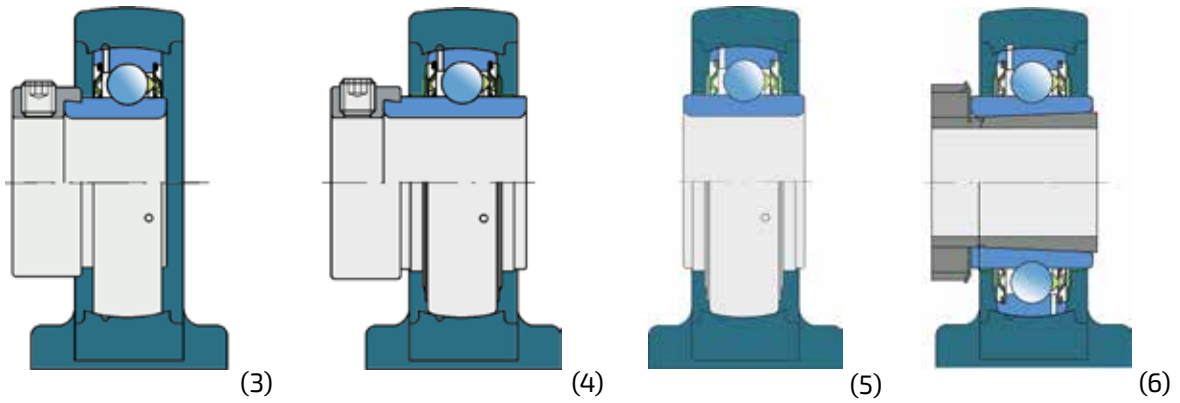

Shaft	Dimensions (mm)											fig.	Mass kg	Designation
	d	L	A	J	H	G	G ₁	H ₁	H ₂	A ₁	s ₁			
40	116	54	84	49,2	M14	20	12	100	31,5	25,3	1	0,56	UEV 208 2S	
											2	1,67	LEV 208 2F	
											3	1,70	UYV 208 2S	
											4	1,79	LYV 208 2F	
											5	1,59	LSV 208 2F	
											6	2,04	LKV 209 2F + H2309	
45	120	54	90	54,2	M14	25	12	108	33,5	25,8	1	1,80	UEV 209 2S	
											2	1,91	LEV 209 2F	
											3	1,89	UYV 209 2S	
											4	1,91	LYV 209 2F	
											5	1,82	LSV 209 2F	
											6	2,53	LKV 210 2F + H2310	
50	130	60	94	57,2	M16	25	14	116	35,5	27,6	1	2,18	UEV 210 2S	
											2	2,33	LEV 210 2F	
											3	2,32	UYV 210 2S	
											4	2,51	LYV 210 2F	
											5	2,24	LSV 210 2F	

3.6.3. Y Bearing Plummer Block Units - Grey Cast Iron Housing "U"

UEU...
LEU...
UYU...
LYU...
LSU...
LKU...

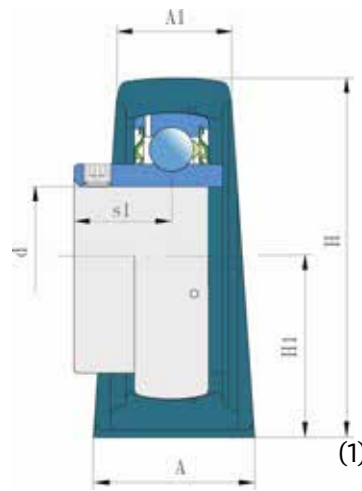
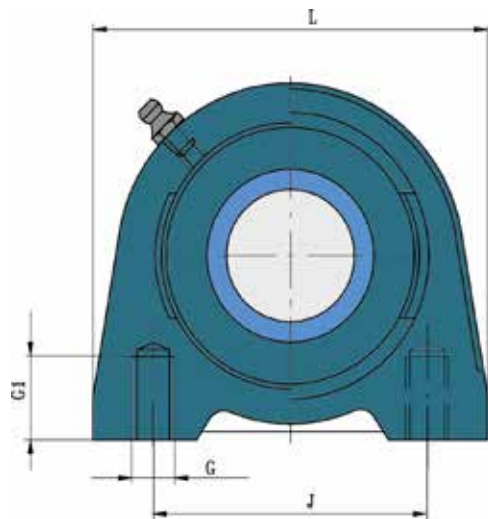

Shaft	Dimensions (mm)										fig.	Mass kg	Designation
	d	L	A	J	H ₁	G	G ₁	H	A ₁	s ₁			
30	98	48	76,2	42,9	M10	15	81,4	25	21	1	0,97	UEU 206 2S	
									22,2	2	1,03	LEU 206 2F	
									26,7	3	1,03	UYU 206 2S	
									30,1	4	1,10	LYU 206 2F	
									14	5	0,97	LSU 206 2F	
									24,3	6	1,53	LKU 207 2F + H2307	
35	103	45	82,6	47,6	M10	15	92,1	27	23,3	1	1,37	UEU 207 2S	
									25,5	2	1,44	LEU 207 2F	
									29,4	3	1,49	UYU 207 2S	
									32,3	4	1,57	LYU 207 2F	
									15,2	5	1,38	LSU 207 2F	
									27	6	1,76	LKU 208 2F + H2308	
	116	48	88,9	49,2	M12	20	98,2	30	27	6	1,76	LKU 208 2F + H2308	

* All bearing units are available from Ductile Cast Iron.

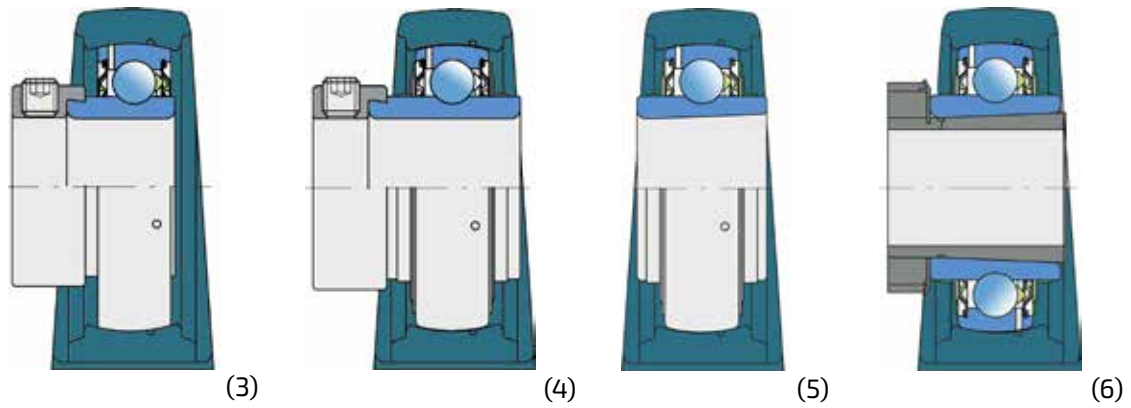

Shaft d	L	A	J	Dimensions (mm)						fig.	Mass kg	Designation
				H ₁	G	G ₁	H	A ₁	s ₁			
40	116	48	88,9	49,2	M12	20	98,2	30	25,3	1	1,56	UEU 208 2S
									30,2	2	1,67	LEU 208 2F
									32,7	3	1,70	UYU 208 2S
									34,9	4	1,79	LYU 208 2F
									17	5	1,59	LSU 208 2F
									28,5	6	2,04	LKU 209 2F + H2309
45	120	48	95,3	54	M12	22	106,5	32	25,8	1	1,80	UEU 209 2S
									30,2	2	1,91	LEU 209 2F
									32,7	3	1,89	UYU 209 2S
									34,9	4	1,91	LYU 209 2F
									17,5	5	1,82	LSU 209 2F
									30,5	6	2,53	LKU 210 2F + H2310
50	135	54	101,6	57,2	M16	25,5	113,2	34	27,6	1	2,18	UEU 210 2S
									32,6	2	2,33	LEU 210 2F
									32,7	3	2,32	UYU 210 2S
									38,1	4	2,51	LYU 210 2F
									20	5	2,24	LSU 210 2F

3.6.4. Y Bearing Flanged Units – Square Grey Cast Iron Housing "F"

UEF...
LEF...
UYF...
LYF...
LSF...
LKF...

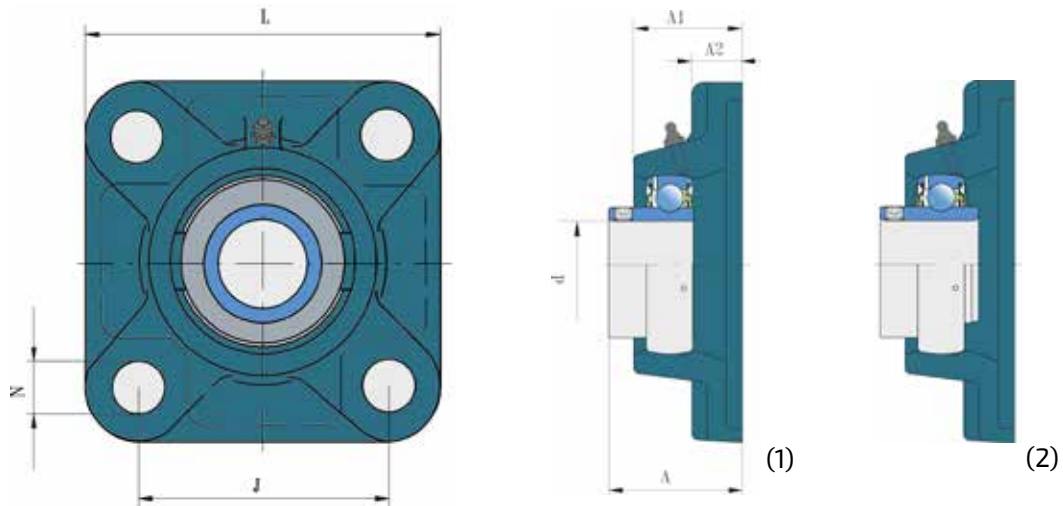

Shaft d	Dimensions (mm)					A	fig.	Mass kg	Designation
	A ₁	A ₂	J	L	N				
17	26	11	54	76	11,5	32,9	1	0,42	UEF 203 2S
						32,9	2	0,44	LEF 203 2F
						39,1	3	0,46	UYF 203 2S
						40,4	4	0,48	LYF 203 2F
20	25,5	11	64	86	12	33,3	1	0,52	UEF 204 2S
						33,3	2	0,54	LEF 204 2F
						38,5	3	0,56	UYF 204 2S
						41,6	4	0,59	LYF 204 2F
						39	6	0,73	LKF 205 2F + H2305
						27	12	70	95
25	27	13	83	95	12	35,5	1	0,70	UEF 205 2S
						35,8	2	0,73	LEtF 205 2F
						39,5	3	0,73	UYF 205 2S
						42,9	4	0,78	LYF 205 2F
						28	5	0,70	LSF 205 2F
						31	13	83	108
30	31	13	83	108	12	39	1	0,94	UEF 206 2S
						40,2	2	1,00	LEF 206 2F
						44,7	3	1,00	UYF 206 2S
						48,1	4	1,07	LYF 206 2F
						32	5	0,94	LSF 206 2F
						34	13	92	118
35	34	13	92	118	14	42,3	1	1,27	UEF 207 2S
						44,5	2	1,34	LEF 207 2F
						48,4	3	1,39	UYF 207 2S
						51,3	4	1,47	LYF 207 2F
						34,3	5	1,28	LSF 207 2F
						36	14	102	130
40	36	14	102	130	16	46,3	1	1,68	UEF 208 2S
						51,2	2	1,79	LEF 208 2F
						53,7	3	1,82	UYF 208 2S
						52,2	4	1,91	LYF 208 2F
						38	5	1,71	LSF 208 2F
						38	16	105	137

* All bearing units are available from Ductile Cast Iron.

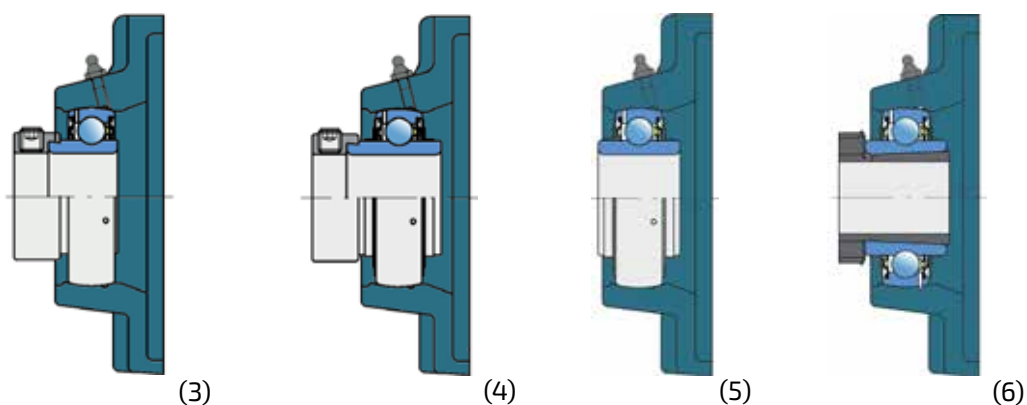

Shaft d	Dimensions (mm)						fig.	Mass kg	Designation
	A ₁	A ₂	J	L	N	A			
45	38	16	105	137	16	47,8	1	2,08	UEF 209 2S
						52,2	2	2,19	LEF 209 2F
						54,7	3	2,19	UYF 209 2S
						56,9	4	2,31	LYF 209 2F
						39,5	5	2,10	LSF 209 2F
						52,5	6	2,80	LKF 210 2F + H2310
50	40	15	111	143	16	49,6	1	2,43	UEF 210 2F
						54,6	2	2,58	LEF 210 2F
						54,7	3	2,57	UYF 210 2S
						60,1	4	2,76	LYF 210 2F
						40,5	5	2,49	LSF 210 2F
						57,5	6	3,60	LKF 211 2F + H2311
55	43	17	130	162	19	58,4	2	3,42	LEF 211 2F
						60,9	3	3,39	UYF 211 2S
						68,6	4	3,60	LYF 211 2F
						45	5	3,39	LSF 211 2F
						63,3	6	4,60	LKF 212 2F + H2312
						68,7	2	4,27	LEF 212 2F
60	48	18	83	175	19	69,3	3	3,84	UYF 212 2F
						75,8	4	4,47	LYC 212 2F
						65,8	6	6,00	LKF 213 2F + H2313
						72,9	2	5,57	LEF 213 2F
						81,6	4	6,10	LYF 213 2F
						73,7	6	7,00	LKF 215 2F + H2315
65	50,3	21,3	152	193	19	70,7	2	6,20	LEF 214 2F
						82,6	4	6,70	LYF 214 2F
						76,5	6	7,80	LKF 216 2F + H2316
						80,3	2	7,00	LEF 215 2F
						88,8	4	7,60	LYF 215 2S
						81,6	2	7,50	LEF 216 2F
70	50,3	21,3	152	193	19	93,6	4	8,34	LYF 216 2F
						88,6	6	11,6	LKF 218 2F + H2318
						94,0	2	11,6	LEF 218 2F
						102,8	4	12,5	LYF 218 2F
						107,5	2	13,9	LEF 220 2F
						93,6	4	13,5	LYF 220 2F

3.6.5. Y Bearing Flanged Units – Oval Grey Cast Iron Housing "N"

UEN...
LEN...
UYN...
LYN...
LSN...
LKN...

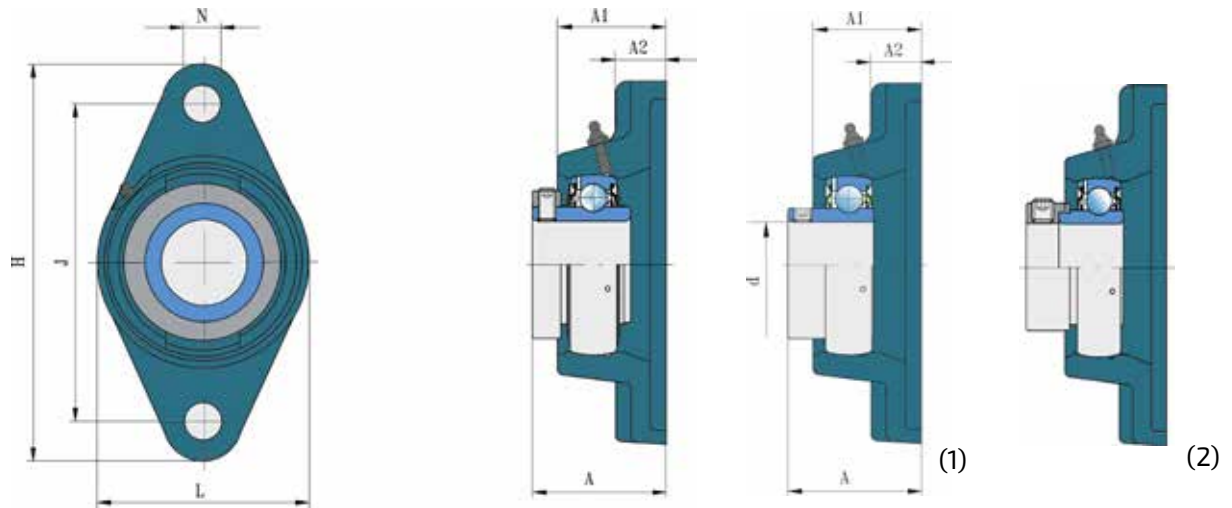

Shaft d	Dimensions (mm)						A	fig.	Mass kg	Designation
	A ₁	A ₂	H	J	L	N				
17	26	11	98,5	76,5	57	11,5	32,9	1	0,37	UEN 203 2S
							32,9	2	0,39	LEN 203 2F
							39,1	3	0,41	UYN 203 2S
							40,4	4	0,43	LYN 203 2F
20	25,5	11	112	90	60	12	33,3	1	0,41	UEN 204 2S
							33,3	2	0,43	LEN 204 2F
							38,5	3	0,45	UYN 204 2S
							41,6	4	0,48	LYN 204 2F
	27	14	130	99	68	16	36	6	0,66	LKN 205 2F + H2305
	25	27	14	130	99	68	16	35,5	1	0,58
35,8								2	0,61	LEN 205 2F
39,5								3	0,61	UYN 205 2S
42,9								4	0,66	LYN 205 2F
28								5	0,56	LSN 205 2F
40,5								6	0,98	LKN 206 2F + H2306
30	30,5	14	148	117	80	16	39	1	0,84	UEN 206 2S
							40,2	2	0,90	LEN 206 2F
							44,7	3	0,90	UYN 206 2S
							48,1	4	0,97	LYN 206 2F
							32	5	0,98	LSN 206 2F
							44,8	6	1,20	LKN 207 2F + H2307
35	34	16	161	130	96	16	42,3	1	1,20	UEN 207 2S
							44,5	2	1,27	LEN 207 2F
							48,4	3	1,32	UYN 207 2S
							51,3	4	1,40	LYN 207 2F
							34,3	5	1,29	LSN 207 2F
							48,5	6	1,60	LKN 208 2F + H2308
40	36	16	175	144	100	16	46,3	1	1,58	UEN 208 2S
							51,2	2	1,69	LEN 208 2F
							53,7	3	1,72	UYN 208 2S
							55,9	4	1,81	LYN 208 2F
							38	5	1,73	LSN 208 2F
							52,5	7	1,95	LKN 209 2F + H2309
							38	18	188	148

* All bearing units are available from Ductile Cast Iron.

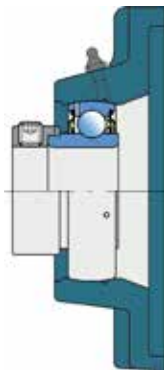

(3)



(4)



(5)

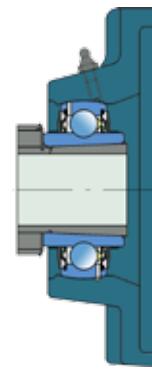

(6)

Shaft	Dimensions (mm)							fig.	Mass kg	Designation						
	d	A ₁	A ₂	H	J	L	N				A					
45	38	18	188	148	108	19	47,8	1	1,73	UEN 209 2S						
							52,2	2	1,84	LEN 209 2F						
							54,7	3	1,84	UYN 209 2S						
							56,9	4	1,96	LYN 209 2F						
							39,5	5	1,86	LSN 209 2F						
							58,5	6	2,10	LKN 209 2F + H2310						
50	40	18	195	157	115	19	49,6	1	1,98	UEN 210 2S						
							54,6	2	2,13	LEN 210 2F						
							54,7	3	2,12	UYN 210 2S						
							60,1	4	2,31	LYN 210 2F						
							40,5	5	2,27	LSN 210 2F						
							63,5	6	3,26	LKN 211 2F + H2311						
55	44	18	220	184	130	19	58,4	2	3,12	LEN 211 2F						
							60,9	3	3,09	UYN 211 2S						
							68,6	4	3,30	LYN 211 2F						
							45	5	3,04	LSN 211 2F						
							48	18	242	202	140	23	70	6	4,07	LKN 212 2F + H2312

3.6.6. Y Bearing Flanged Units - Round Grey Cast Iron Housing "G"

UEG...
LEG...
UYG...
LYG...
LSG...
LKG...

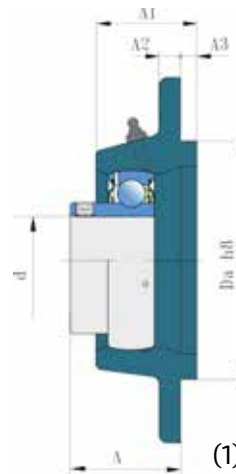
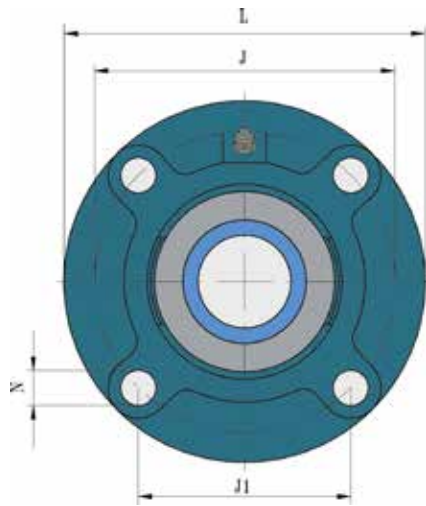

Shaft		Dimensions (mm)							Mass		Designation	
d	A ₁	A ₂	A ₃	D _a	J	J ₁	L	N	A	fig.		kg
20	25,5	7	5	62	78	55,1	100	12	28,3	1	0,65	UEG 204 2S
									28,3	2	0,67	LEG 204 2F
									33,5	3	0,69	UYG 204 2S
									36,6	4	0,72	LYG 204 2F
	27	7	6	70	90	63,6	115	12	30	6	0,78	LKG 205 2F + H2305
	25	27	7	6	70	90	63,6	115	12	29,5	1	0,95
29,5										2	0,98	LEG 205 2F
33,5										3	0,98	UYG 205 2S
36,9										4	1,03	LYG 205 2F
20,5										5	0,93	LSG 205 2F
31		8	8	80	100	70,7	125	12	32	6	1,45	LKG 206 2F + H2306
30	31	8	8	80	100	70,7	125	12	31	1	1,34	UEG 206 2S
									32,2	2	1,40	LEG 206 2F
									36,7	3	1,40	UYG 206 2S
									40,1	4	1,47	LYG 206 2F
									23	5	1,48	LSG 206 2F
	34	9	8	90	110	77,8	135	14	35,3	6	1,60	LKG 207 2F + H2307
35	34	9	8	90	110	77,8	135	14	34,3	1	1,57	UEG 207 2S
									36,5	2	1,64	LEG 207 2F
									40,4	3	1,69	UYG 207 2S
									43,3	4	1,77	LYG 207 2F
									23,8	5	1,66	LSG 207 2F
	36	9	10	100	120	84,8	145	14	38,5	6	2,10	LKG 208 2F + H2308
40	36	9	10	100	120	84,8	145	14	36,3	1	1,78	UEG 208 2S
									41,2	2	1,89	LEG 208 2F
									43,7	3	1,92	UYG 208 2S
									45,9	4	2,01	LYG 208 2F
									24,5	5	1,93	LSG 208 2F
	38	14	12	105	132	93,3	160	16	38,5	6	2,75	LKG 209 2F + H2309

* All bearing units are available from Ductile Cast Iron.



(3)



(4)



(5)



(6)

Shaft		Dimensions (mm)								Mass		Designation
d	A ₁	A ₂	A ₃	D _a	J	J ₁	L	N	A	fig	kg	
45	38	14	12	105	132	93,3	160	16	35,8	1	2,53	UEG 209 2S
									40,2	2	2,64	LEG 209 2F
									42,7	3	2,64	UYG 209 2S
									44,9	4	2,76	LYG 209 2F
									24	5	2,66	LSG 209 2F
									40	6	3,00	LKG 210 2F + H2310
50	40	14	12	110	138	97,6	165	16	37,6	1	2,78	UEG 210 2S
									42,6	2	2,93	LEG 210 2F
									42,7	3	2,92	UYG 210 2S
									48,1	4	3,11	LYG 210 2F
									24	5	3,07	LSG 210 2F
									43	6	3,26	LKG 211 2F + H2311
55	43	15	12	125	150	106,1	185	19	46,4	2	4,07	LEG 211 2F
									48,9	3	4,04	UYG 211 2S
									56,6	4	4,25	LYG 211 2F
									27,5	5	3,99	LSG 211 2F
									48	6	4,07	LKG 212 2F + H2312
60	48	15	12	135	160	113,1	195	19	56,7	2	5,02	LEG 212 2F
									57,3	3	4,59	UYG 212 2S
									63,8	4	5,22	LYG 212 2F
65	50	15	14	145	170	120,2	205	19	58,9	2	5,85	LEG 213 2F
									67,6	4	6,59	LYG 213 2F

3.6.7. Y Bearing Take - Up Units - Grey Cast Iron Housings "T"

UET...
LET...
UYT...
LYT...
LST...
LKT...

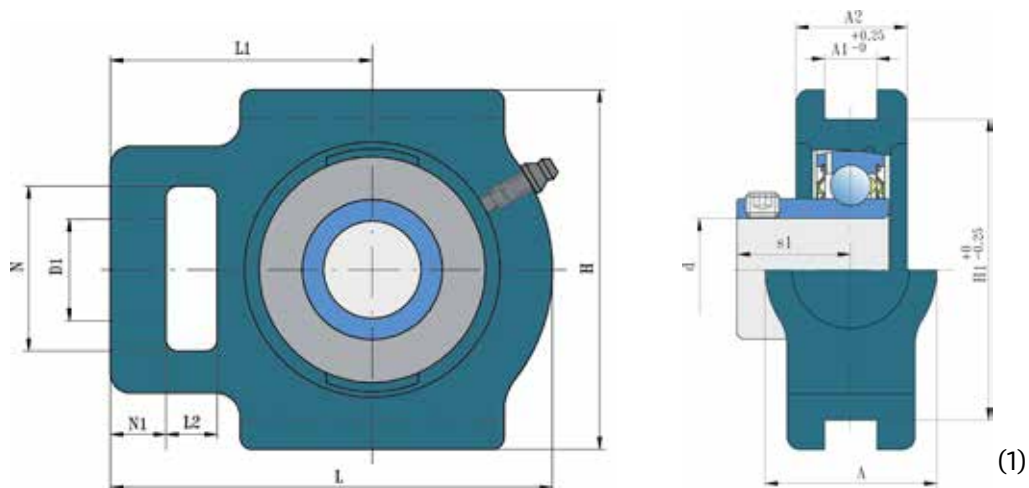

Shaft d	Dimensions (mm)											fig.	Mass kg	Designation	
	A	A ₂	D _a	H	L	L ₁	L ₂	N	N ₁	A ₁	H ₁				
20	34	52	19	92	97	62	16	32	10	13,5	76	18,3	1	0,89	UET 204 2S
												18,3	2	0,91	LET 204 2F
												23,5	3	0,93	UYT 204 2S
												26,6	4	0,96	LYT 204 2F
	23,5	6	0,94	LKT 205 2F + H2305											
	25	34	25	19	91	100	64	16	33	10	13,5	76	19,5	1	0,85
19,8													2	0,88	LET 205 2F
23,5													3	0,88	UYT 205 2S
16,9													4	0,93	LYT 205 2F
11,5													5	0,85	LST 205 2F
25													6	1,37	LKT 206 2F + H2306
30	37	28	22	104	114	70	16	37	10	13,5	89	21	1	1,21	UET 206 2S
												22,2	2	1,27	LET 206 2F
												26,7	3	1,27	UYT 206 2S
												30,1	4	1,34	LYT 206 2F
												13	5	1,21	LST 206 2F
												29,5	6	1,66	LKT 207 2F + H2307
35	37	30	22	103	129	78	17	38	12	13,5	89	23,3	1	1,50	UET 207 2S
												25,5	2	1,57	LET 207 2F
												29,4	3	1,62	UYT 207 2S
												32,3	4	1,70	LYT 207 2F
												13,5	5	1,51	LST 207 2F
												31,5	6	2,43	LKT 208 2F + H2308
40	49	33	29	115	145	88	19	50	15	17,5	101	25,3	1	2,23	UET 208 2S
												30,2	2	2,34	LET 208 2F
												32,7	3	2,37	UYT 208 2S
												34,9	4	2,46	LYT 208 2F
												14,5	5	2,26	LST 208 2F
												35	6	2,47	LKT 209 2F + H2309

* All bearing units are available with Ductile Cast Iron.

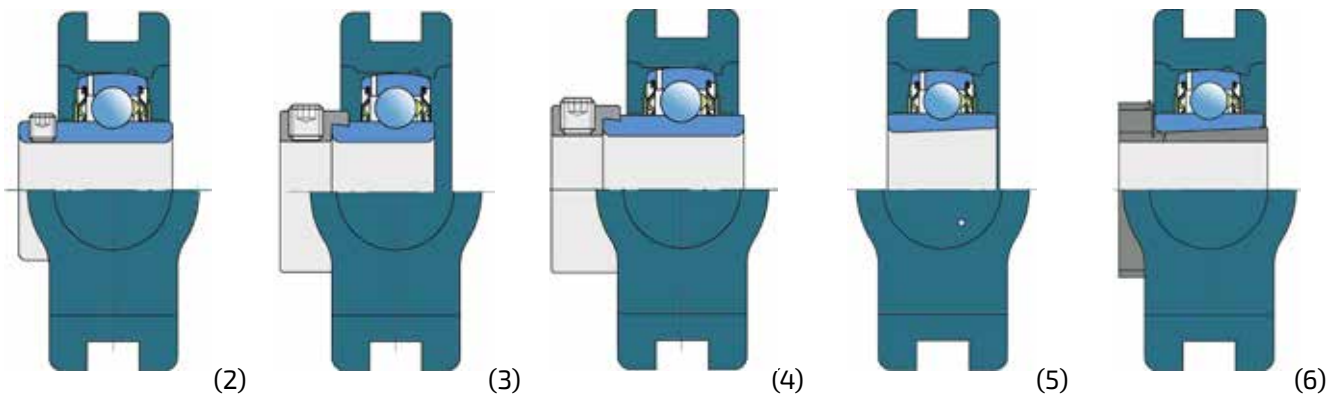

Shaft	Dimensions (mm)												fig.	Mass kg	Designation
	d	A	A ₂	D _a	H	L	L ₁	L ₂	N	N ₁	A ₁	H ₁			
45	49	35	29	117	144	87	19	49	15	17,5	101	25,8	1	2,23	UET 209 2S
												30,2	2	2,34	LET 209 2F
												32,7	3	2,34	UYT 209 2S
												34,9	4	2,46	LYT 209 2F
												15	5	2,25	LST 209 2F
												39,5	6	2,63	LKT 210 2F + H2310
50	49	36	29	117	149	90	19	49	16	17,5	101	27,6	1	2,28	UET 210 2S
												32,6	2	2,43	LET 210 2F
												32,7	3	2,42	UYT 210 2S
												38,1	4	2,61	LYT 210 2F
												15,5	5	2,34	LST 210 2F
												42,5	6	4,16	LKT 211 2F + H2311
55	64	41	35	146	171	106	25	64	19	27	130	33,4	2	4,02	LET 211 2F
												35,9	3	3,99	UYT 211 2S
												43,6	4	4,20	LYT 211 2F
												16,5	5	3,99	LST 211 2F

3.6.8. Y Bearing Flanged Units - Round Pressed Steel Housing "C"

UEC...
LEC...
UYC...
LYC...

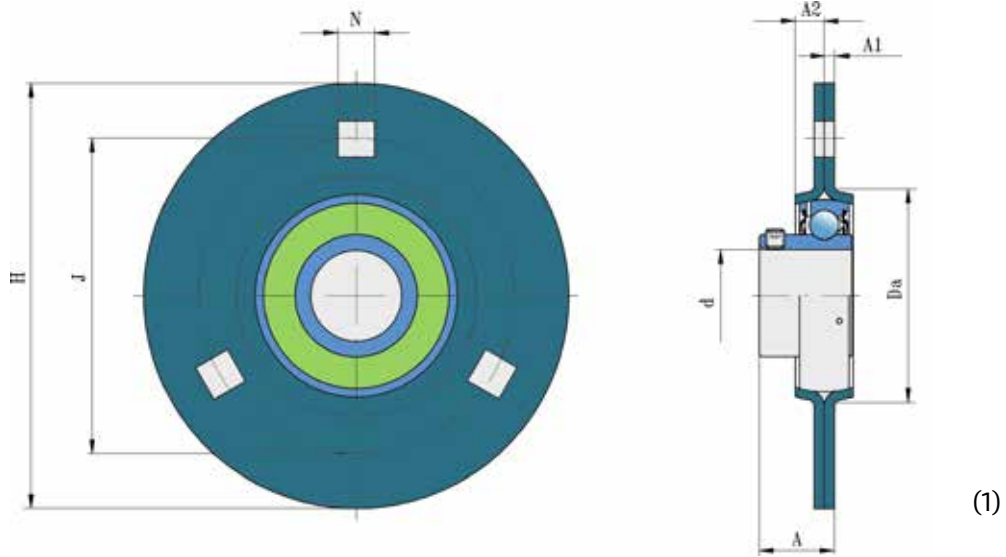

(1)

Shaft		Dimensions (mm)						Perm. load (kN)		Mass	Designation	
d	A ₁	A ₂	D _a	H	J	N	A	rad.	axial	fig.		kg
17	2	7	49	81	63	7,1	17,9	2,5	1,2	1	0,20	UEC 203 2S
							17,9			2	0,22	LEC 203 2F
							24,1			3	0,24	UYC 203 2S
							24,3			4	0,26	LYC 203 2F
20	2	8	55	91	71,5	8,7	20,3	3,3	1,6	1	0,28	UEC 204 2S
							20,3			2	0,30	LEC 204 2F
							25,5			3	0,32	UYC 204 2S
							28,6			4	0,35	LYC 204 2F
25	2	9	60	95	76	8,7	21,5	3,6	1,8	1	0,33	UEC 205 2S
							21,8			2	0,36	LEC 205 2F
							25,5			3	0,36	UYC 205 2S
							28,9			4	0,41	LYC 205 2F
30	2,5	9,5	71	112	90,5	10,5	23,5	5,0	2,5	1	0,52	UEC 206 2S
							24,7			2	0,58	LEC 206 2F
							29,2			3	0,58	UYC 206 2S
							32,6			4	0,65	LYC 206 2F
35	2,5	10,5	81	122	100	10,5	25,8	6,5	3,2	1	0,69	UEC 207 2S
							28			2	0,76	LEC 207 2F
							31,9			3	0,81	UYC 207 2S
							34,8			4	0,89	LYC 207 2F

* Housing C 208 and larger have 4 locking holes.

* All combinations with other types of Y bearings are possible.

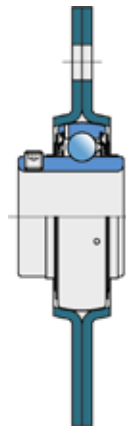

(2)

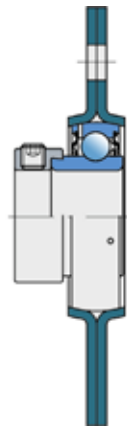

(3)

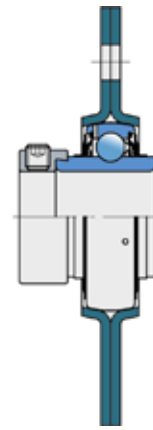

(4)

Shaft		Dimensions (mm)						Perm. load (kN)		Mass	Designation	
d	A ₁	A ₂	D _a	H	J	N	A	rad.	axial	fig.		kg
40	3,5	11	91	148	119	13,5	28,8	7,5	3,7	1	1,16	UEC 208 2S
							33,7			2	1,27	LEC 208 2F
							36,2			3	1,30	UYC 208 2S
							38,4			4	1,39	LYC 208 2F
45	3,5	11,5	96	149	120,5	13,5	29,3	8,3	4,1	1	1,23	UEC 209 2S
							33,7			2	1,34	LEC 209 2F
							36,2			3	1,34	UYC 209 2S
							38,4			4	1,46	LYC 209 2F
50	4	2	102	155	127	13,5	31,6	9	4,5	1	1,44	UEC 210 2S
							36,6			2	1,59	LEC 210 2F
							36,7			3	1,58	UYC 210 2S
							42,1			4	1,77	LYC 210 2F
55	4	12,5	112	167	138	13,5	37,4	9,5	4,8	2	2,02	LEC 211 2F
							39,9			3	1,99	UYC 211 2S
							47,6			4	2,20	LYC 211 2F
60	4	13	122	176	148	13,5	43,7	9,5	4,8	2	2,67	LEC 212 2F
							44,3			3	2,24	UYC 212 2S
							50,8			4	2,87	LYC 212 2F

3.6.9. Y Bearing Flanged Units - Triangular Pressed Steel Housing "D"

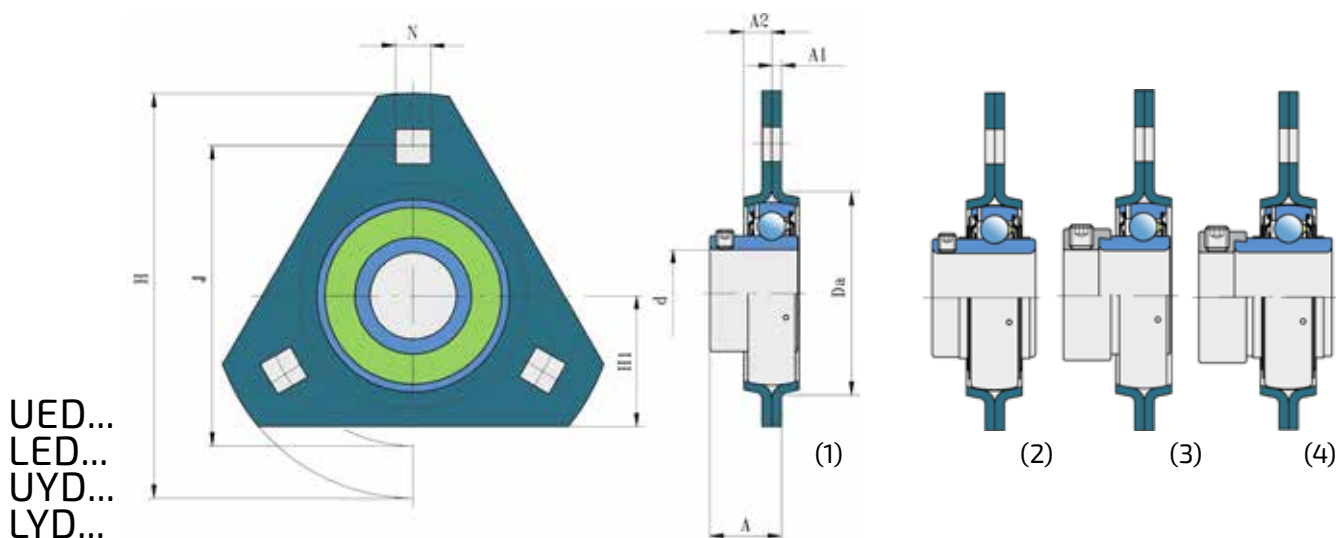

UED...
LED...
UYD...
LYD...

Shaft	Dimensions (mm)							Perm.load (kN)		fig.	Mass (kg)	Designation	
	d	A ₁	A ₂	D _a	H	H ₁	J	N	A				rad.
25	2	9	60	95	34	76	8,7	21,5	3,6	1,8	1	0,31	UED 205 2S
								21,8			2	0,34	LED 205 2F
								25,5			3	0,34	UYD 205 2S
								28,9			4	0,39	LYD 205 2F
30	2,5	9,5	71	112	38	90,5	10,5	23,5	5,0	2,5	1	0,43	UED 206 2S
								24,7			2	0,49	LED 206 2F
								29,2			3	0,49	UYD 206 2S
								32,6			4	0,56	LYD 206 2F
35	2,5	10,5	81	122	45	100	10,5	25,8	6,5	3,2	1	0,65	UED 207 2S
								28			2	0,72	LED 207 2F
								31,9			3	0,77	UYD 207 2S
								34,8			4	0,85	LYD 207 2F

* All combinations with other types of Y bearings are possible.

3.6.10. Y Bearing Flanged Units - Oval Pressed Steel Housing "P"

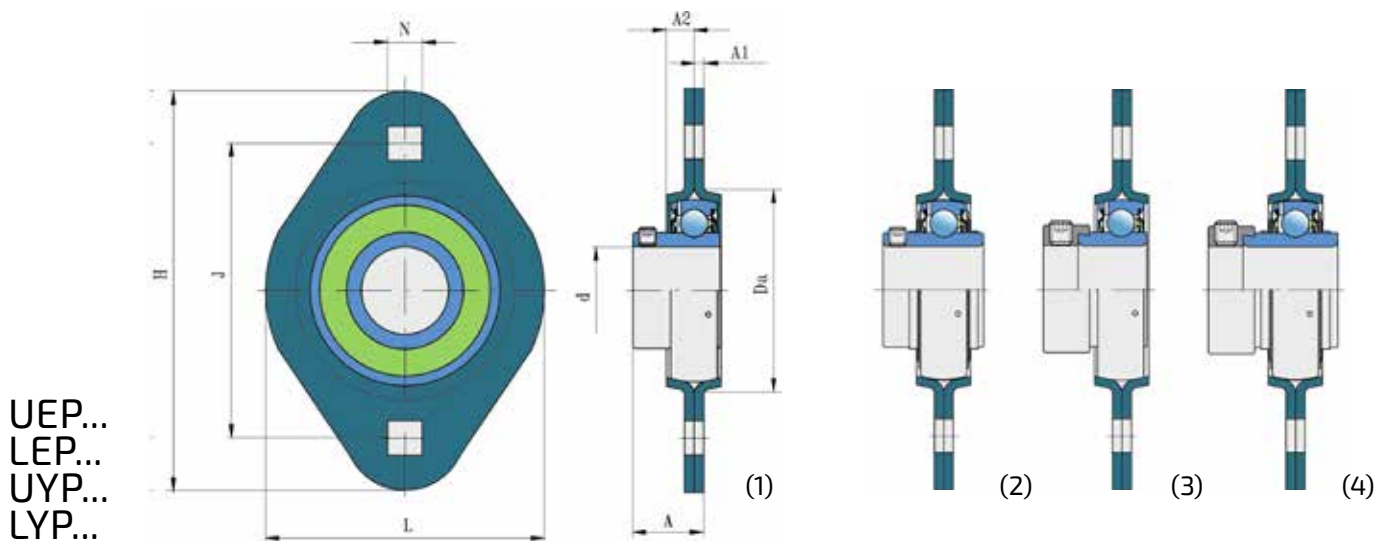

UEP...
LEP...
UYP...
LYP...

Shaft d	Dimensions (mm)							Perm.load (kN)		fig.	Mass kg	Designation	
	A ₁	A ₂	D _a	H	L	J	N	A	rad.				axial
20	2	8	55	91	67	71,5	8,7	20,3	3,3	1,6	1	0,21	UEP 204 2S
								20,3			2	0,23	LEP 204 2F
								25,5			3	0,25	UYP 204 2S
								28,6			4	0,28	LYP 204 2F
25	2	9	60	95	71	76	8,7	21,5	3,6	1,8	1	0,26	UEP 205 2S
								21,8			2	0,29	LEP 205 2F
								25,5			3	0,29	UYP 205 2S
								28,9			4	0,34	LYP 205 2F
30	2,5	9,5	71	112	84	90,5	10,5	23,5	5,0	2,5	1	0,40	UEP 206 2S
								24,7			2	0,46	LEP 206 2F
								29,2			3	0,46	UYP 206 2S
								32,6			4	0,53	LYP 206 2F
35	2,5	10,5	81	122	94	100	10,5	25,8	6,5	3,2	1	0,60	UEP 207 2S
								28			2	0,67	LEP 207 2F
								31,9			3	0,72	UYP 207 2S
								34,8			4	0,80	LYP 207 2F
40	3,5	11	91	148	100	119	13,5	28,8	7,5	3,7	1	0,83	UEP 208 2S
								33,7			2	0,94	LEP 208 2F
								36,2			3	0,97	UYP 208 2S
								38,4			4	1,06	LYP 208 2F

* All combinations with other types of Y bearings are possible.

3.7. Disc Harrow Bearings First Generation

3.7.1. Round and Square Bore Series with Spherical Outer Ring - Non Relubricable Type

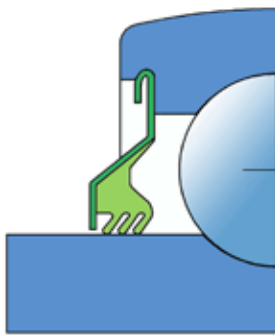

...2T

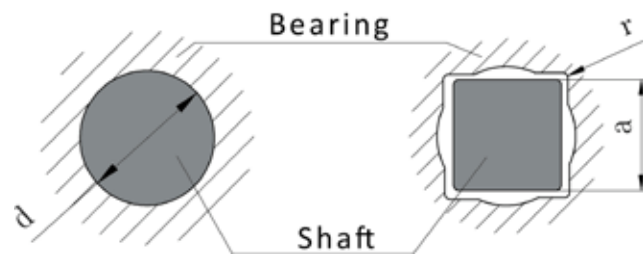

Bore d		D		B		C		d ₁	
inch	mm	inch	mm	inch	mm	inch	mm	inch	mm
1,5005	38,113	3,1496	80	1,688	42,96	0,709	18	2,047	52
1,1880	30,17			1,188	30,18	1,188	30,18		
1,1880	30,17			1,188	30,18	0,709	18		
1,5005	38,113			1,688	42,96	1,188	30,18		
1,7717	45	3,3465	85	1,188	30,18	1,188	30,18	2,228	56,6
1,5350	39			1,188	30,18	1,188	30,18		
1,7811	45,24			1,438	36,53	0,866	22		
1,9380	49,23	3,5433	90	1,188	30,18	1,188	30,18	2,461	62,5
1,7811	45,34			1,188	30,18	1,188	30,18		
2,1880	55,58	3,39370	100	1,312	33,34	1,312	33,34	2,720	69,1

Shaft size a

1 1/8	28,6	3,1496	80	1,438	36,53	0,709	18	2,047	52
1	25,4	3,1496	80			0,709	18		
1 1/8	28,6	3,1496	80			1,188	30,18		
1	25,4	3,1496	80			1,188	30,18		
7/8	22,2	3,3755	85,74			1,188	30,18		
1 1/8	28,6	3,3755	85,74			1,188	30,18		
7/8	22,2	3,1496	80			0,709	18		
7/8	22,2	3,4385	87,34			1,188	30,18		
1 1/8	28,6	3,4385	87,34			1,188	30,18		
1 1/4	31,8	3,3465	85	1,438	36,53	1,188	30,18	2,228	56,6
1 1/4	31,8	3,4385	87,34	1,438	36,53	1,188	30,18		
1 1/4	31,8	3,3465	85	1,438	36,53	0,748	19		
1 1/8	28,6	3,5433	90	1,188	30,18	1,188	30,18	2,461	62,5
1 1/8	28,6	3,5433	90	1,438	36,53	1,188	30,18		
1 1/2	38,1	3,9370	100	1,312	33,34	1,312	33,34	2,720	69,1
1 1/2	38,1	4,1250	104,77	1,750	44,45	1,438	36,53		
1 1/2	38,1	4,0770	103,56	1,750	44,45	1,438	36,53		

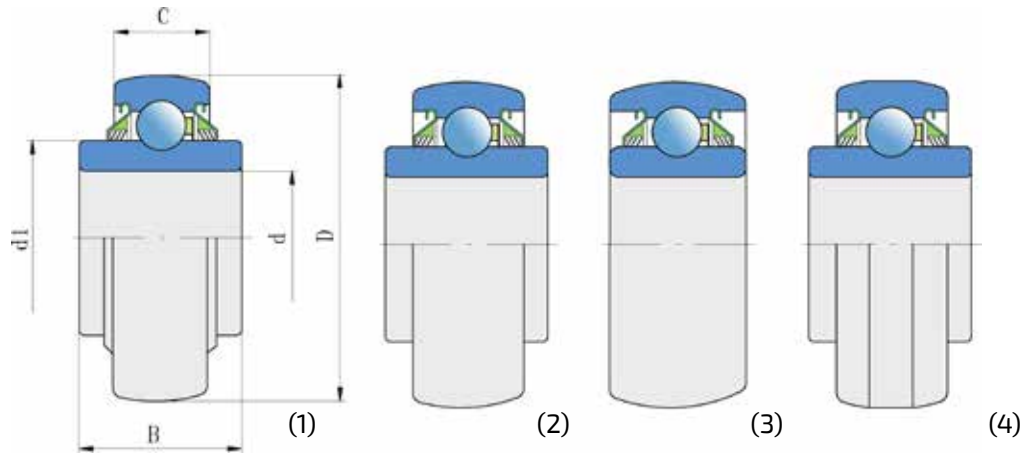

Load ratings (kN)						ROUND BORE		
C		C ₀		Mass		Designation	Type	
lbs.	kN	lbs.	kN	lbs.	kg			
7300	32,5	4400	19,8	1,59	0,72	W208PPB2	1	
				1,60	0,73	W208PPB4	3	
				1,41	0,64	W208PPB7	1	
				1,50	0,68	W208PPB23	1	
7300	32,5	4600	20,4	1,44	0,65	W209PPB2	3	
				1,65	0,75	W209PPB4	3	
				1,34	0,62	W209PPB11	1	
7800	35,0	5200	23,2	1,56	0,71	W210PPB2	3	
				1,75	0,79	W210PPB5	3	
9700	43,5	6500	29,0	2,13	0,97	W211PPB2	3	

SQUARE BORE							
7300	32,5	4400	19,8	1,47	0,68	W208PPB5	1
				1,59	0,72	W208PPB6	1
				1,70	0,77	W208PPB8	2
				1,90	0,86	W208PPB9	2
				2,20	1,00	W208PPB11	4
				2,09	0,95	W208PPB12	4
				1,62	0,74	W208PPB13	1
				2,05	0,93	W208PPB18	4
				1,87	0,85	W208PPB19	4
7300	32,5	4600	20,4	1,75	0,79	W209PPB5	1
				1,85	0,84	W208PPB7	4
				1,65	0,75	W209PPB8	1
7800	35,0	5200	23,2	2,11	0,96	W210PPB4	3
				2,25	1,02	W210PPB6	1
9700	43,5	6500	29,0	2,66	1,21	W211PPB3	3
				4,10	1,86	W211PPB5	4
				3,83	1,74	W211PPB6	4

3.7.2. Round and Square Bore Series with Cylindrical Outer Ring - Non Relubricable Type

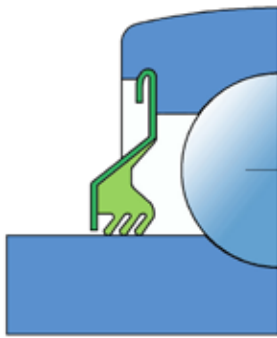

...2T

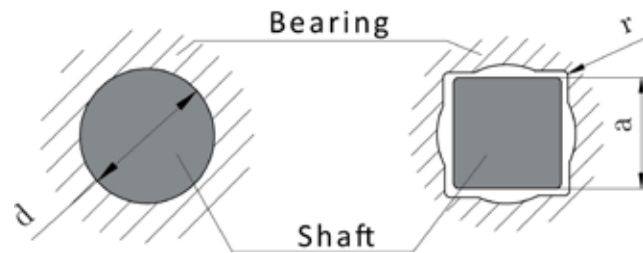

Bore d		D		B		C		d ₁	
inch	mm	inch	mm	inch	mm	inch	mm	inch	mm
0,628	15,95	1,988	50,5	0,591	15	0,591	15	1,082	27,5
1,531	38,89	3,15	80	1,083	27,5	0,827	21	2,024	51,4
1,1880	30,17	3,1496	80	1,188	30,18	1,188	30,18	2,047	52
1,1880	30,17			1,188	30,18	0,709	18		
1,5005	38,113			1,687	42,85	0,827	21		
1,9380	49,23	3,5433	90	1,188	30,18	1,188	30,18	2,461	62,5
1,5300	38,86			1,188	30,18	1,188	30,18		
2,1880	55,58			1,312	33,34	1,312	33,34		

Shaft size a

	25	2,8346	72	1,771	45	0,945	24	1,815	46,1
1 1/4	31,8	3,1496	80	1,438	36,53	0,709	18	2,047	52
1	25,4					0,709	18		
1 1/8	28,6					1,188	30,18		
1 1/8	28,6					0,709	18		
	30	3,3465	85	1,771	45	1,188	30,18	2,228	56,6
1 1/8	28,6	3,5433	90	1,188	30,18	1,188	30,18	2,461	62,5
1 1/2	38,1	3,9370	100	1,312	33,34	1,312	33,34	2,720	69,1
1 1/2	38,1	4	101,6	1,750	44,45	1,438	36,52		

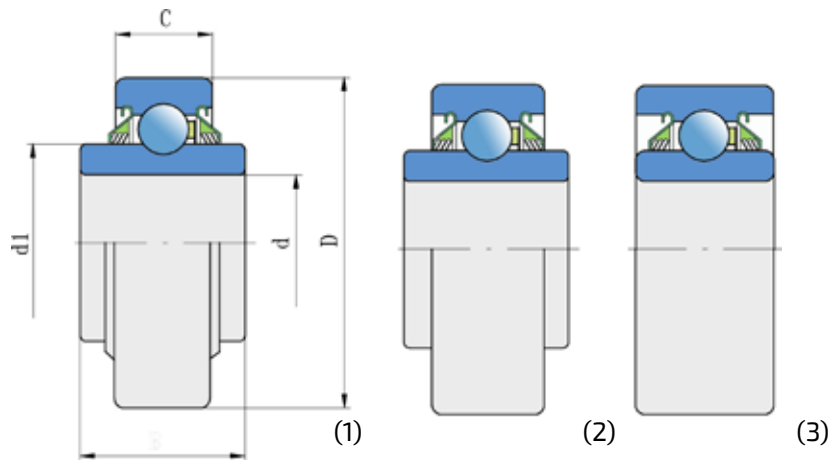

Load ratings (kN)						ROUND BORE		
C		C ₀		Mass		Designation	Type	
lbs.	kN	lbs.	kN	lbs.	kg			
2855	12,7	1470	6,55	0,55	0,25	203KRR3	3	
5306	23,6	4270	19	1,01	0,46	208KRR4	2	
7300	32,5	4400	19,8	1,68	0,76	W208PP4	3	
				1,43	0,65	W208PP7	1	
				1,50	0,68	W208PP10	1	
7800	35,0	5200	23,2	1,69	0,77	W210PP2	3	
				1,97	0,89	W210PP9	3	
				2,33	1,06	W211PP2	3	

SQUARE BORE							
5700	25,5	3400	15,3	1,65	0,75	W207PP3	1
7300	32,5	4400	19,8	1,50	0,68	W208PP5	1
				1,62	0,73	W208PP6	1
				1,66	0,75	W209PP8	1
				2,50	0,68	W209PP20	1
7300	32,5	4600	20,4	2,16	0,98	W209PP3	2
7800	35,0	5200	23,2	1,92	0,87	W210PP4	3
9700	43,5	6500	29,0	2,79	1,27	W211PP3	3
				3,48	1,58	W211PP5	1

3.7.3. Round and Square Bore Series – Relubricable Type

3.7.3.1. Round Bore Series

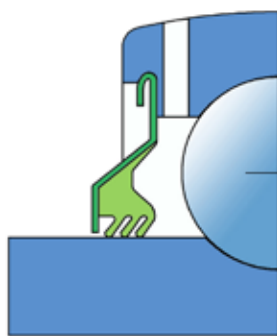

...2T

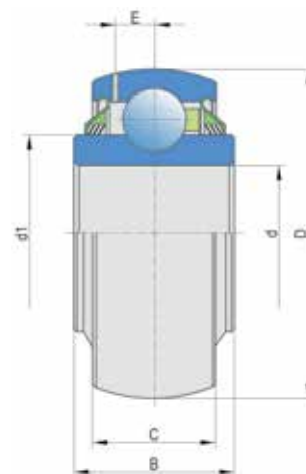
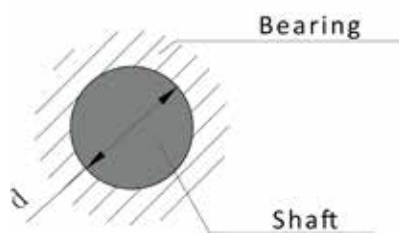

Bore d		D		B		C		d ₁		E	
inch	mm	inch	mm	inch	mm	inch	mm	inch	mm	inch	mm
1,7717	45	3,3465	85	1,188	30,18	1,188	30,18	2,228	56,6	0,256	6,5
1,5350	39			1,188	30,18	1,188	30,18				
1,7810	45,24			1,438	36,53	0,866	22				
1,7650	44,831			1,687	42,85	0,866	22				
1,77	45,24	3,346	85	1,438	36,53	1,185	30,1				
1,5	38,11	3,3456	85	1,687	42,85	0,866	22				
1,781	44,958	3,492	88,7	1,687	42,86	1,25	31,75				
1,575	40	3,346	85	1,687	42,85	0,866	22				
1,9380	49,23	3,5433	90	1,188	30,18	1,188	30,18	2,461	62,5	0,260	6,6
1,4065	35,73			1,188	30,18	1,188	30,18				
1,7850	45,34			1,188	30,18	1,188	30,18				
1,9450	49,40			1,438	36,53	0,906	23				
2,1880	55,58	3,3970	100	1,312	33,34	1,312	33,34	2,720	69,1	0,279	7,1
2,1880	55,58			1,312	33,34	1,312	33,34				
1,6600	42,16			1,312	33,34	1,312	33,34				
2,1880	55,58			1,312	33,34	0,984	25				
2,1950	55,75			1,562	39,69	0,984	25				
2,1950	55,75			1,562	39,69	0,984	25				
1,9380	49,23			1,312	33,34	1,312	33,34				
1,7850	45,34			1,312	33,34	0,984	25				
1,7850	45,34			1,312	33,34	0,984	25				
2,02	51,31			2,374	60,3	1,312	33,34				
1,78	45,21			1,752	44,5	1,312	33,34				
2,0150	51,18			1,312	33,34	0,984	25				
2,1880	55,58			2,187	55,5	0,984	25				
2,1880	55,57			2,187	55,5	0,984	25				
2,1880	55,58			1,575	40	0,984	25				
2,1880	55,57			1,543	39,7	1,315	33,4				

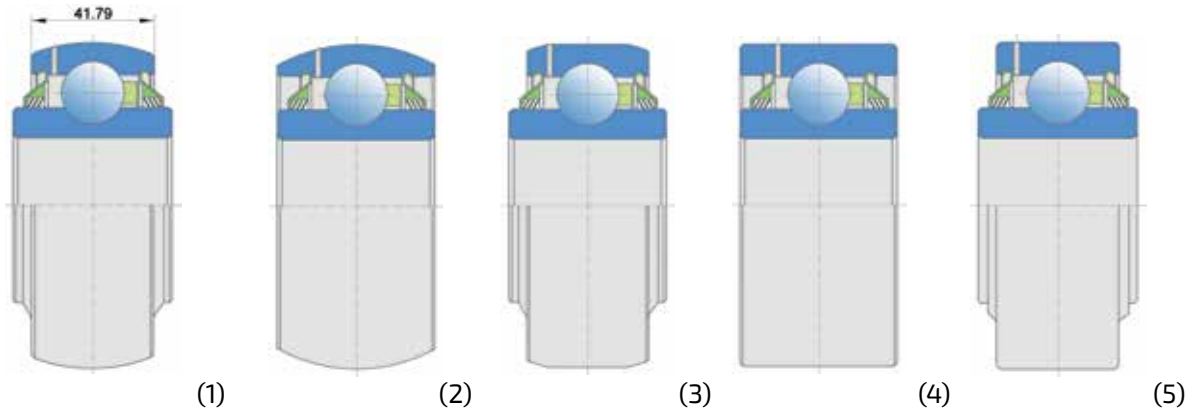

Load ratings (kN)							
C		C ₀		Mass		Designation	Type
lbs.	kN	lbs.	kN	lbs.	kg		
7300	32,5	4600	20,4	1,44	0,65	GW209PPB2	2
				1,65	0,75	GW209PPB4	2
				1,37	0,62	GW209PPB11	1
				1,50	0,68	GW209PPB12	1
				1,41	0,645	GW209PPB13	1
				1,76	0,8	GW209PPB38	1
				2,03	0,92	GW209PPB30	3
				1,72	0,78	GW209PPB40	1
				7800	35,0	5200	23,2
2,25	1,02	GW210PP3	4				
1,75	0,79	GW210PPB5	2				
1,75	0,79	GW210PP9	5				
9700	43,5	6500	29,0	3,00	1,36	GW211PP2	4
				2,62	1,19	GW211PPB2	2
				3,00	1,36	GW211PP4	4
				1,85	0,84	GW211PPB8	1
				2,02	0,92	GW211PPB9	1
				2,02	0,92	GW211PP9	5
				2,26	1,03	GW211PPB10	2
				2,02	0,92	GW211PPB13	1
				2,02	0,92	GW211PP13	5
				2,45	1,11	GW211PP202	5
				2,45	1,11	GW211PP25	5
				2,00	0,91	GW211PPB14	1
				2,18	0,99	GW211PPB15	1
				2,00	0,91	GW211PPB15X1	1
				2,03	0,92	GW211PPB16	1
2,21	1,03	GW211PPB20	1				

3.7.3.2. Square Bore Series

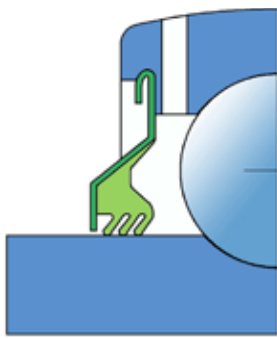

...2T

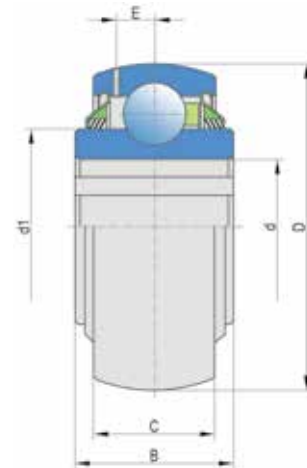
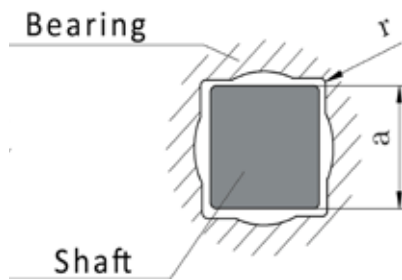

Schaft size a		D		B		C		d ₁		E	
inch	mm	inch	mm	inch	mm	inch	mm	inch	mm	inch	mm
1 1/8	28,6	3,3758	85,74	1,438	36,53	1,188	30,18	2,05	52	0,256	6,5
1 1/8	28,6	3,5433	90	1,188	30,18	1,188	30,18	2,461	62,5	0,260	6,6
1 1/2	38,1	3,397	100	1,312	33,33	1,312	33,33	2,72	69,1	0,279	7,1
1 1/2	38,1	3,397	100	1,750	44,45	1,312	33,33	2,72	69,1	0,279	7,1
1,77	45,24	3,346	85	1,438	36,53	1,185	30,1				
1,781	44,958	3,492	88,7	1,687	42,86	1,25	31,75				
1,575	40	3,346	85	1,687	42,85	0,866	22				
1 1/8	28,6	3,1496	80	1,438	36,53	0,827	21	2,05	52	0,256	6,5
1	25	3,1496	80			0,827	21			0,256	6,5
1 1/8	28,6	3,1496	80			1,188	30,18			0,260	6,6
1 1/8	28,6	3,3578	85,74			1,188	30,18			0,260	6,6
1 1/8	28,6	3,3578	85,74			1,188	30,18			0,26	6,6
1,18	30	3,3465	85	1,771	45	1,188	30,18	2,228	56,6	0,260	6,6
1,18	30			1,438	36,53	1,188	30,18			0,260	6,6
1	25			1,771	45	1,188	30,18			0,260	6,6
1,29	32,8			1,438	36,53	1,188	30,18			0,260	6,6
1,29	32,8			1,438	36,53	0,866	22			0,256	6,5
1	25			1,687	42,85	0,866	22			0,256	6,5
1,29	32,8			1,687	42,85	0,866	22			0,256	6,5
1,18	30			1,771	45	0,866	22			0,256	6,5
1 1/8	28,6	3,5433	90	1,188	30,18	1,188	30,18	2,461	62,5	0,260	6,6
1 1/2	38,1	3,397	100	1,312	33,34	1,312	33,34	2,72	69,1	0,279	7,1
1 1/2	38,1			1,752	44,5	1,312	33,34				
1,59	40,5			1,771	45	0,984	25				
1,54	39,25			2,187	55,55	0,984	25				
1,38	35			2,187	55,55	0,984	25				
1,59	40,5			2,187	55,55	0,984	25				
1,59	40,5			1,771	45	0,984	25				

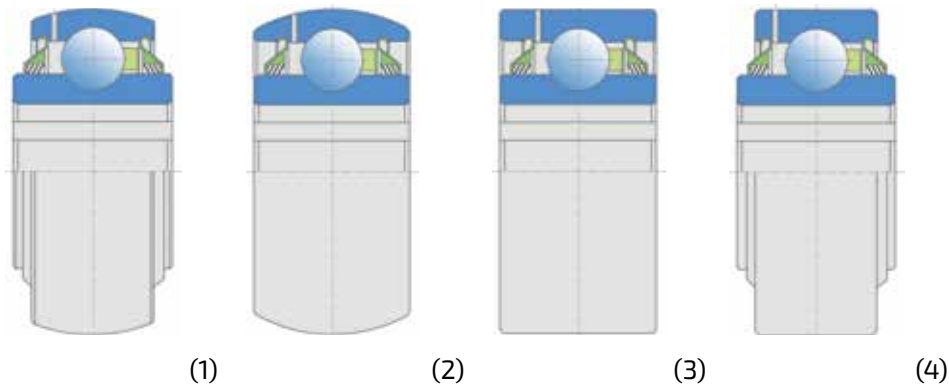

Load ratings (kN)							
lbs.	C		lbs.	Mass		Designation	Type
	kN	C ₀		kN	lbs.		
7300	32,5	4400	19,8	2,04	0,925	GW208PP17	4
7800	35,0	5200	23,2	2,31	1,048	GW210PP4	4
9700	43,5	6500	29,0	2,79	1,266	GW211PP3	4
9700	43,5	6500	29,0	2,62	1,188	GW211PP17	4
				1,41	0,645	GW209PPB13	1
				2,03	0,92	GW209PPB30	3
				1,72	0,78	GW209PPB40	1
7300	32,5	4400	19,8	1,48	0,67	GW208PPB5	1
				1,48	0,67	GW208PPB6	1
				1,75	0,79	GW208PPB8	1
				1,92	0,871	GW208PPB12	1
				2,01	0,912	GW208PPB17	1
7300	32,5	4600	20,4	1,87	0,85	GW209PPB3	1
				1,75	0,794	GW209PPB3.X1	1
				2,16	0,98	GW209PPB3.X2	1
				1,75	0,79	GW209PPB5	1
				1,65	0,748	GW209PPB8	1
				2,02	0,92	GW209PPB26	1
				1,87	0,85	GW209PPB29	1
				2,02	0,92	GW209PPB32	1
7800	35	5200	23,2	1,75	0,794	GW210PPB4	2
9700	43,5	6500	29	2,66	1,207	GW211PPB3	2
				2,56	1,16	GW211PPB17	1
				2,18	0,99	GW211PPB40	1
				2,73	1,24	GW211PPB40.X1	1
				2,87	1,30	GW211PPB40.X2	1
				2,69	1,22	GW211PPB40.X3	1
				2,25	1,02	GW211PPBJ40	1

3.7.4. Hexagonal Bore Series

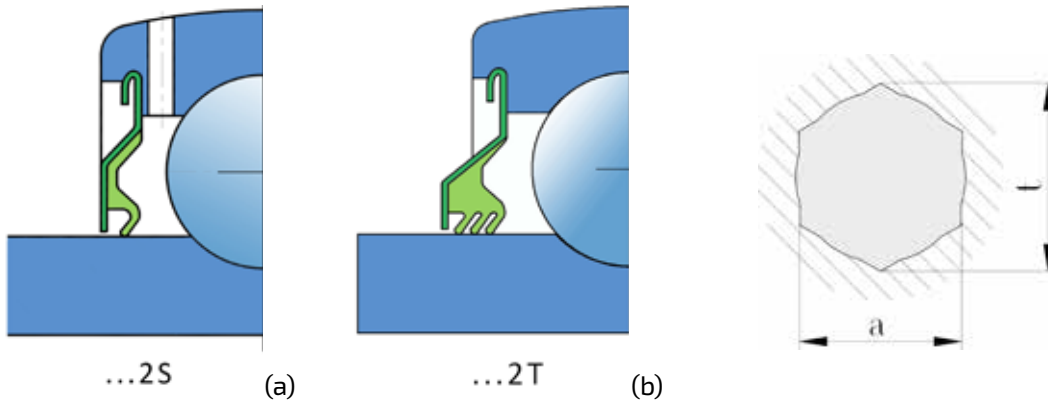

Shaft	Dimensions (mm)													
	a		$t_{min.}$		D		B		C		d_1		E	
	inch	mm	inch	mm	inch	mm	inch	mm	inch	mm	inch	mm	inch	mm
11/16	0,6949	17,65	0,797	20,24	1,85	47	0,825	20,96	0,551	14	1,11	28,2		
11/16	0,6949	17,65	0,797	20,24	1,85	47	0,825	20,96	0,551	14	1,11	28,2		
7/8	0,876	22,225	1,010	25,65	2,0472	52	1	25,4	0,591	15	1,323	33,6		
1	1,001	25,43	1,152	29,26	2,4409	62	0,945	24	0,630	16	1,563	39,7		
11/4	1,251	31,77	1,443	36,35	2,8346	72	1,484	37,7	0,669	17	1,815	46,1		
11/4	1,251	31,77	1,443	36,35			0,984	25						
11/8	1,126	28,6	1,298	32,97			1,484	37,7						
11/8	1,126	28,6	1,298	32,97			1,484	37,7						
11/8	1,126	28,6	1,298	32,97			0,984	25	0,748	19				
11/8	1,126	28,6	1,298	32,97			0,984	25						
11/4	1,251	31,77	1,443	36,35			0,984	25						
11/4	1,251	31,77	1,443	36,35			0,984	25	0,748	19	1,815	46,1		
11/4	1,251	31,78					1,496	38						
11/4	1,251	31,77	1,443	36,65	3,1496	80	1,438	36,53	0,709	18	2,047	52		
	1,251	31,78	1,435	36,46			1,437	36,5						
11/2	1,501	38,12	1,730	43,94	3,3456	85	1,181	30	0,748	19	2,228	56,6		
						90			0,866	22	2,461	62,5		
1	1,001	25,43	1,152	29,26	2,4409	62	0,945	24	0,709	18	1,563	39,7	0,201	5,1
11/4	1,251	31,78	1,435	36,46	2,8346	72	1,496	38	0,748	19	1,815	46,1		

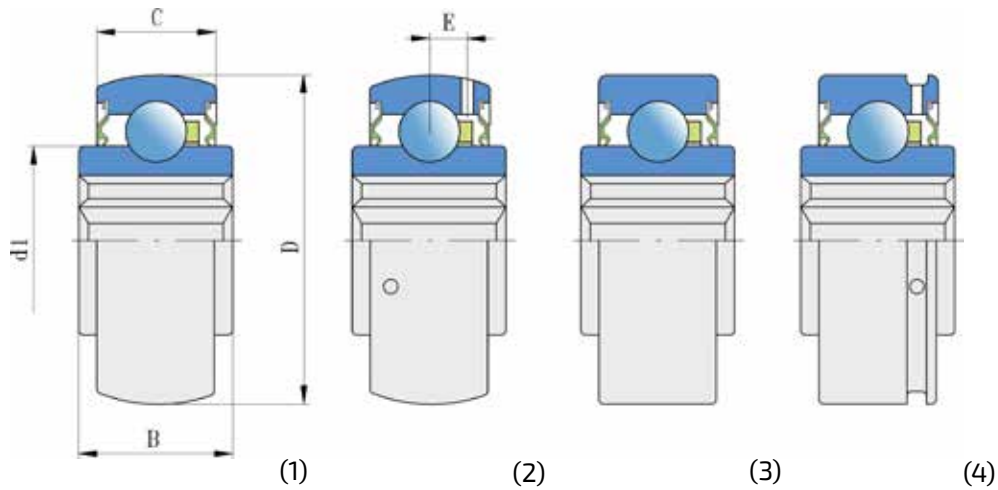

Load ratings						NON RELUBRICABLE TYPE			
C		C ₀		Mass		Designation			
lbs	kN	lbs	kN	lbs.	kg	Seal Fig. a	Type	Seal Fig. b	Type
2203	9,8	1472	6,55	0,287	0,13	204KRR2	3		
2203	9,8	1472	6,55	0,43	0,195	204KRRB2	1		
3100	14,0	1700	7,8	0,44	0,20			205KPPB2	1
						205KRR2	3		
						205KRRB2	1		
								205PP13	3
								205PPB13	1
4400	19,5	2500	11,3	0,76	0,35			206KPP3	3
				0,76	0,35			206KPPB3	1
				0,75	0,34	206KRR6	3		
				0,75	0,34	206KRRB6	1		
5700	25,5	3400	15,3	1,00	0,45			207KPP3	3
				0,87	0,40			207KPPB3	1
				1,00	0,45	207KRRB9			1
				1,00	0,45	207KRRB12	1	207KPP9	
				0,87	0,40	207KRRB12C19	1		
				0,94	0,42	207KRR17	1		
				0,87	0,40	207KRRB17	3		
				0,87	0,40		1		1
				1,44	0,65			207KPPB31	
7300	32,5	4400	19,8	1,45	0,66			W208PPB16	1
						W208KRR8	3		
				1,499	0,68			W208KPP8	3
				1,499				W208PP16	3
7300	32,5	4600	20,4	1,27	0,58	209KRRB2	1		
								209KPPB2	1
7870	35	5216	23,2	1,76	0,8	210RRB6	1		
RELUBRICABLE TYPE									
4400	19,5	2500	11,3	0,62	0,28	G206KRRB6	2		
5700	25,5	3400	15,3	1,433	0,65			G207KPP3AH16	4

3.8. Disc Harrow Bearing Units First Generation

3.8.1. Square Series

Type 1.

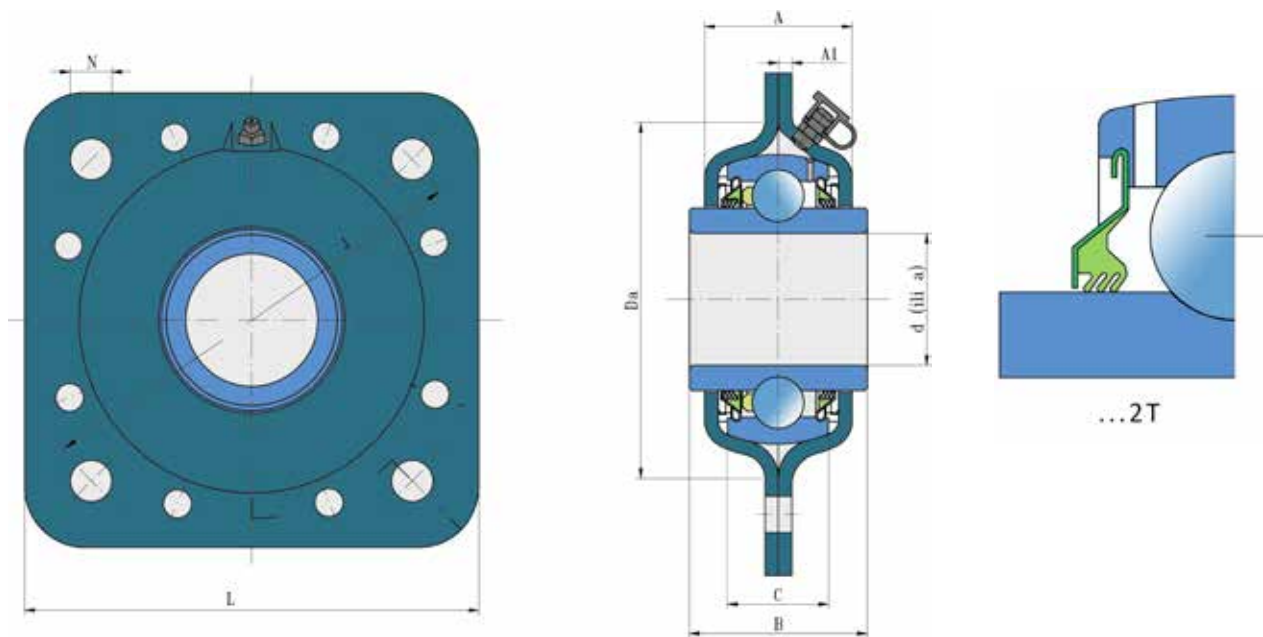

a-square mm	Shaft size		Dimensions (mm)							
	inch	d-cylindrical bore mm	B	A	A ₁	C	D _a	L	J	N
25	1,7650	44,831	42,85	39	3,5	22	97	127	114	13,5
30	1	25								
32,8										
30										
30			45							
		38,11	42,85							
		38,7								
	1,5748	40								
38,9	2,1880	55,58	55,55	44,7	4	31,8	113	140	127	13,5
40,5			33,34			25				
39,25			45			26,5				
35			55,55			25				
40,5			55,55							
40,5			45							
40,5			45							
40,5			55,55							
	2,1653	55	55			31,5				

Type 2.

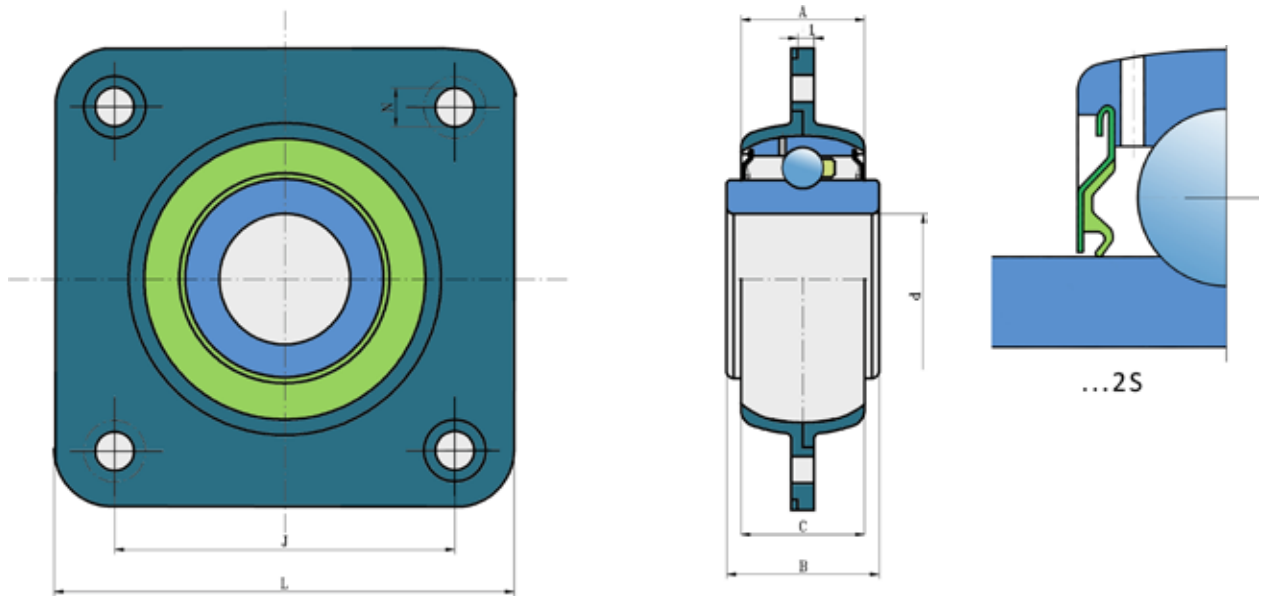

Recommendations for max. load							
radial		axial		Mass		Type	Designation
lbs	kN	lbs	kN	lbs	kg		
1750	7,7	860	3,8	3,32	1,51	1	GWST 209PPB12
				3,92	1,51	1	GWST 209PPB25
				3,92	1,78	1	GWST 209PPB26
				3,72	1,69	1	GWST 209PPB28
				3,56	1,62	1	GWST 209PPB29
				3,72	1,69	1	GWST 209PPB31
				3,90	1,77	1	GWST 209PPB32
				3,56	1,62	1	GWST 209PPB38
				3,56	1,62	1	GWST 209PPB39
				3,56	1,62	1	GWST 209PPB40
				2200	9,8	1150	5,1
4,95	2,25	1	GWST 211PPB39				
4,95	2,25	1	GWST 211PPB40				
5,39	2,45	1	GWST 211PPB40.X1				
5,83	2,65	1	GWST 211PPB40.X2				
5,39	2,45	1	GWST 211PPB43				
4,97	2,26	1	GWST 211PPBP40				
4,97	2,26	1	GWST 211PPBJ40				
4,97	2,26	1	GWST 211PPBP40.X3				
4,55	2,07	1	LSST 211 X3-3				

3.8.2. Round Series

Type 1.

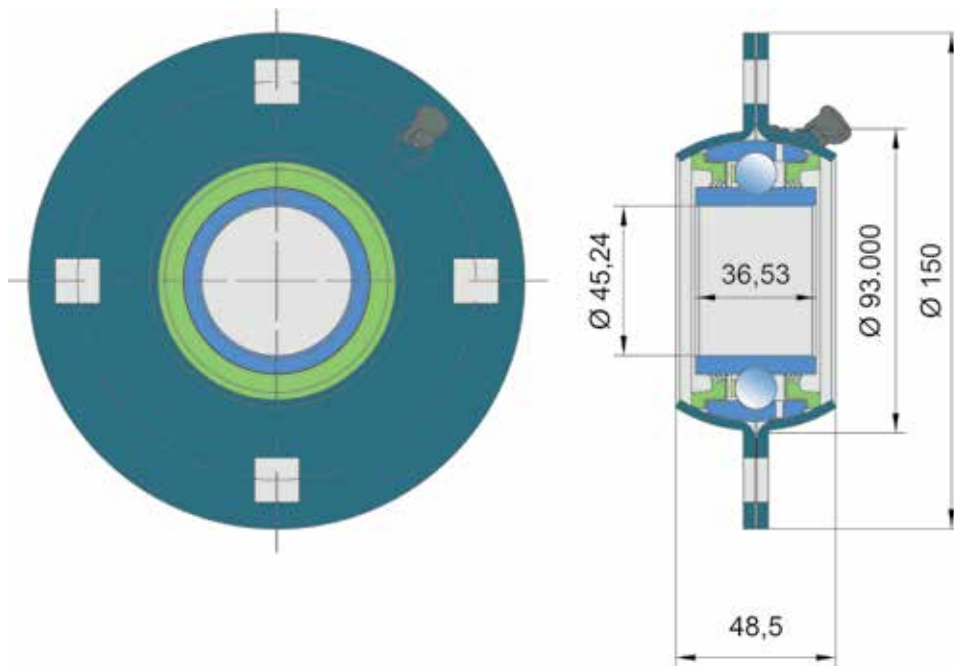

a-square mm	inch	d-cylindrical bore mm	Dimensions (mm)							
			B	A	A ₁	C	D _a	D	J	N
1,781		45,24	36,53	48,5	3,5	30,1	93	150	120,5	13,5
2,193		55,7	39,7	56,4	3,5	33,4	111	167	138	13,5

* Maintenance free option is also available (Type 2.)

Type 2.

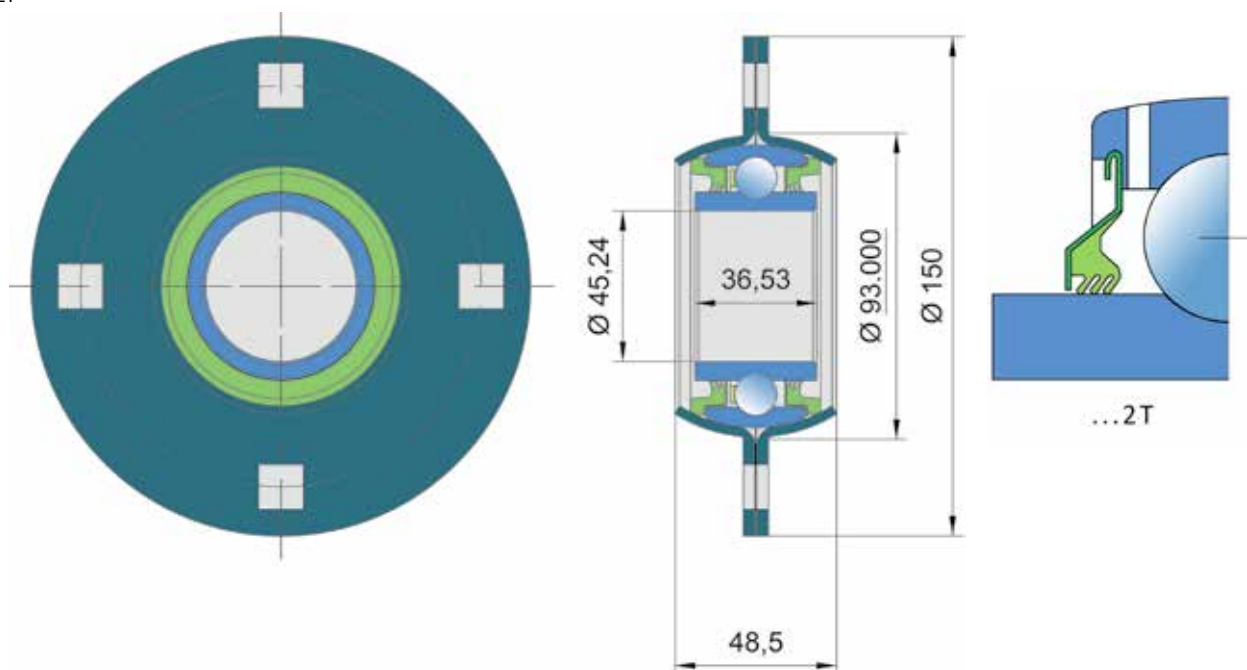

Recommendations for max. load								
radial		axial		Mass		Type	Designation	
lbs	kN	lbs	kN	lbs	kg			
1750	9,8	860	3,8	4,048	1,836	1	GWST 209PPB13	
2200	9,8	1150	5,1	5,478	2,485	1	GWST 211PPB20	

3.9. Disc Harrow Bearings Second Generation

Development of modern agricultural machinery has increased the demand of bearings for soil preparation machinery. There is a requirement that each plate should have its own compact bearing, in order to reduce the costs of dismounting and mounting during maintenance, as well as request for better sealing and permanent lubrication of bearings.

Design

Design of double row angular contact ball bearings for agricultural application has derived from the design of the wheel bearings.

Rigid bearing arrangement needs reduced and constant axial clearance that does not depend on the skills of final user but is provided by design and bearing production technology.

Rings and balls are made of special bearing steel. One bearing is mounted on a single plate.

Force

As opposite from classical disc harrow bearings, these bearings can support both axial force and torque.

Sealing and lubrication

Bearing are permanently lubricated with grease for agricultural machinery at a rate of 60-80% of the free volume. These bearings have rubber-metal seals. It is also necessary to add the final sealing.

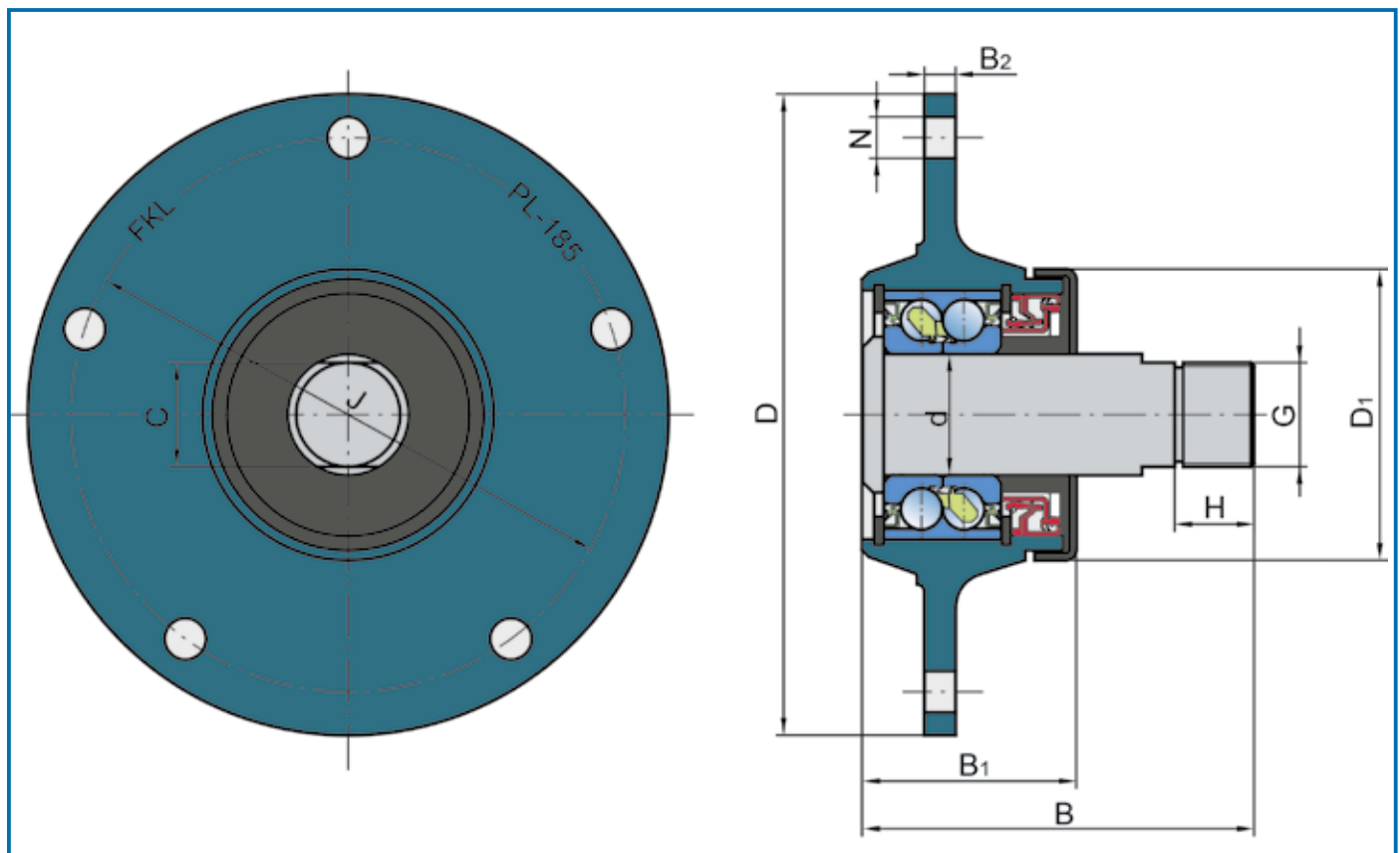

Fig.13. Disc harrow bearing

3.10. Disc Harrow Bearings Third Generation

Further development of agricultural machinery led to more compact solution, integrated bearing with flange named IL-50.

Design of double row angular contact ball bearings

The internal design is the same as of bearings of the second generation, with an even smaller axial clearance that remains the same after the installation.

Inner rings and balls material is a special bearing steel. Flange is made out of improved high quality induction hardened steel.

Longer bearing's life span due to powerful cassette sealing and 30% bigger loading capacity than the corresponding values from the second generation.

Shaft

Shaft is incorporated in the bearing and is locked after mounting with a screw nut M22x1,5.

Sealing and lubrication

They are permanently lubricated with grease for agricultural machinery at the rate of 60-80% of free volume. Labyrinth contact sealing with the cassette seal provides long-term life for the whole bearing unit. Bearing also has additional sealing with RS seals.

Flanges with outer ring

4/5/6 holes are evenly distributed over the flange at 98 mm diameter. Plate is mounted to the flange with M12x1,25 screws. The entire flange is painted - anti corrosion protected.

Designation	J	H/T	d	C	M	E	F	L	kg	Interchange
IL50-98.4T-M22	98	4xM12x1,25	27,95	25,4	M22x1,5	17	25	102	2,5	IL2-117-M22-D
IL50-98.5T-M22	98	5xM12x1,25	27,95	25,4	M22x1,5	17	25	102	2,5	IL2-117-M22-G
IL50-98.6T-M22	98	6xM12x1,25	30	25,4	M22x1,5	17	25	102	2,5	IL2-117-M22-I
IL50-98.4T-M24	98	4xM12x1,25	30	27,5	M24x2	17	29	106	2,55	IL2-117-M24-H
IL50-98.6T-M24	98	6xM12x1,25	30	27,5	M24x2	17	29	106	2,55	IL2-117-M24-D
IL50-100.4T-1"	100	4xM12x1,25	30	27,5	1"SEA14h	36	29	125	2,65	IL2-117-1"
IL50-100.6T-M24-R	100	6xM12x1,25	27,95	27	M24x1,5	15,5	22	97,5	2,65	5554512-LEMKEN
IL50-100.6T-M24-L	100	6xM12x1,25	27,95	27	M24x1,5-left	15,5	22	97,5	2,5	5554513-LEMKEN
IL50-98.4T-B30.F	98	4xM12x1.25	-	-	-	-	-	-	1,9	IL-117-F
IL50-98.4T-B30.J	98	4xM12x1.25	-	-	-	-	-	-	1,9	IL-117-J

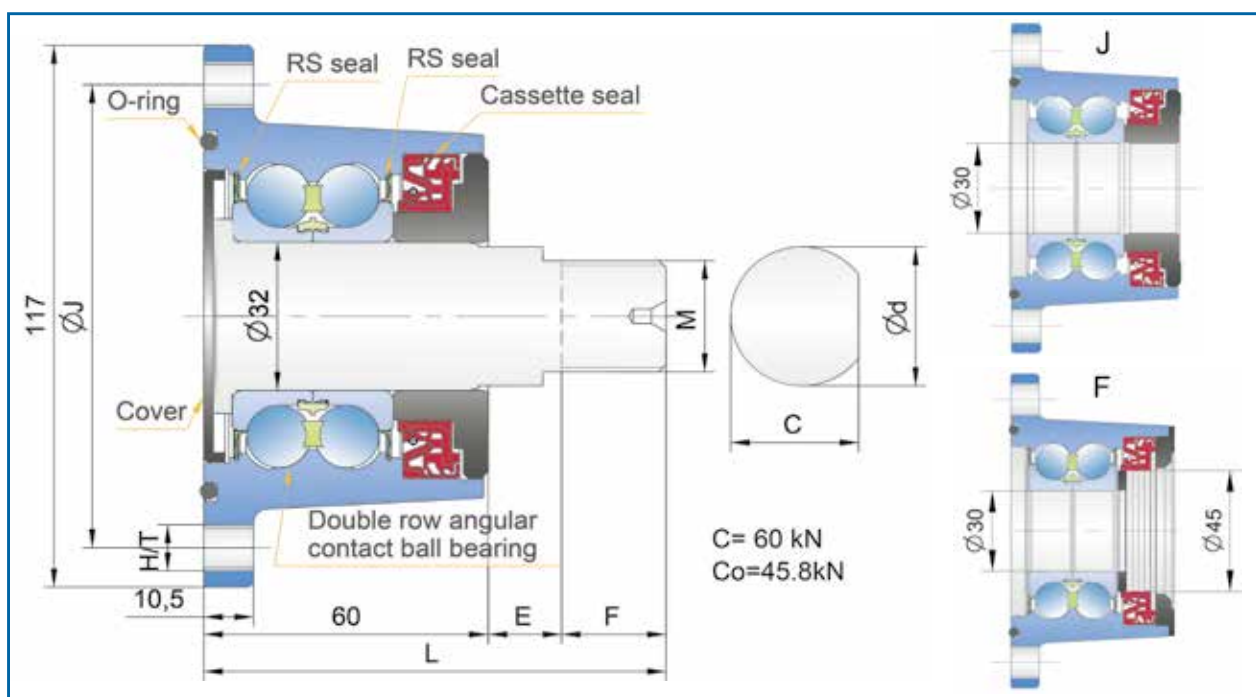

Fig.14. Technical drawing bearing unit IL-50

3.11. Bearing Units Type 2TB

By the requests of the agricultural equipment manufacturers in addition to the standard Y program FKL has developed special versions of bearings with a variety of improvements in construction, primarily in order to extend the life of bearing to the end-users satisfaction. In agriculture, good sealing means longevity and accordingly LEF 200 2TB series of bearing units with better sealing have been developed. They carry an additional designation 2TB, but have the same size as series LEF 200 2F.

Triple-lip seals (2T)

Instead of one-lip seals triple-lip seals are installed and this solution has been implemented for number of years. Seal has a steel reinforcement which is further zinc galvanized so it has good anti corrosion protection. Strong triple lips are made of NBR rubber resistant to lubricants and fuels. Between the lips there are 3 compartments for grease storage, which retain impurities, this preventing the penetration of dirt to the balls. More detailed info about 2T sealing see on page 10.

Protective flinger

As additional protection from rough dirt (grass, wires, strings,...) and mechanical impact of foreign matters, increased thickness 1,5-2 mm reinforced rubber protection flinger was added. Increased thickness and surface protection (blued) ensure longer operation life despite the influence of various external atmospheric agents (water, acids,...).

Flinger is fitted interference a solid flap on the inner ring so it provides a good additional protection. Flinger has protection function to the seal. Since mounted in front of it, prevents rough dirt penetration and provide protection against mechanical impact.

Lubrication

These series are enabled for additional lubrication by means of lubricators. Cone countersinks are made at angle of 120° , one per side. This results in better flow and entry of grease which makes easier to bring grease in the contact zone of balls and raceways. Grease flow is better due to the increased diameter of the intake grease hole.

Housing material

Material selected for 2TB housings is Gray Cast Iron EN-GJL-200 but also can be ductile iron EN-GJS-500-7 which has many advantages comparing to Gray Cast Iron in terms of the strength of structure, resistance to shocks, vibrations, abrasion and therefore longer life span.

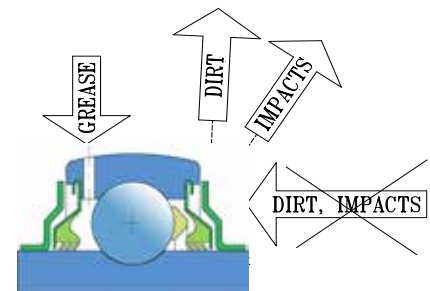

Fig.15. Sealing 2TB

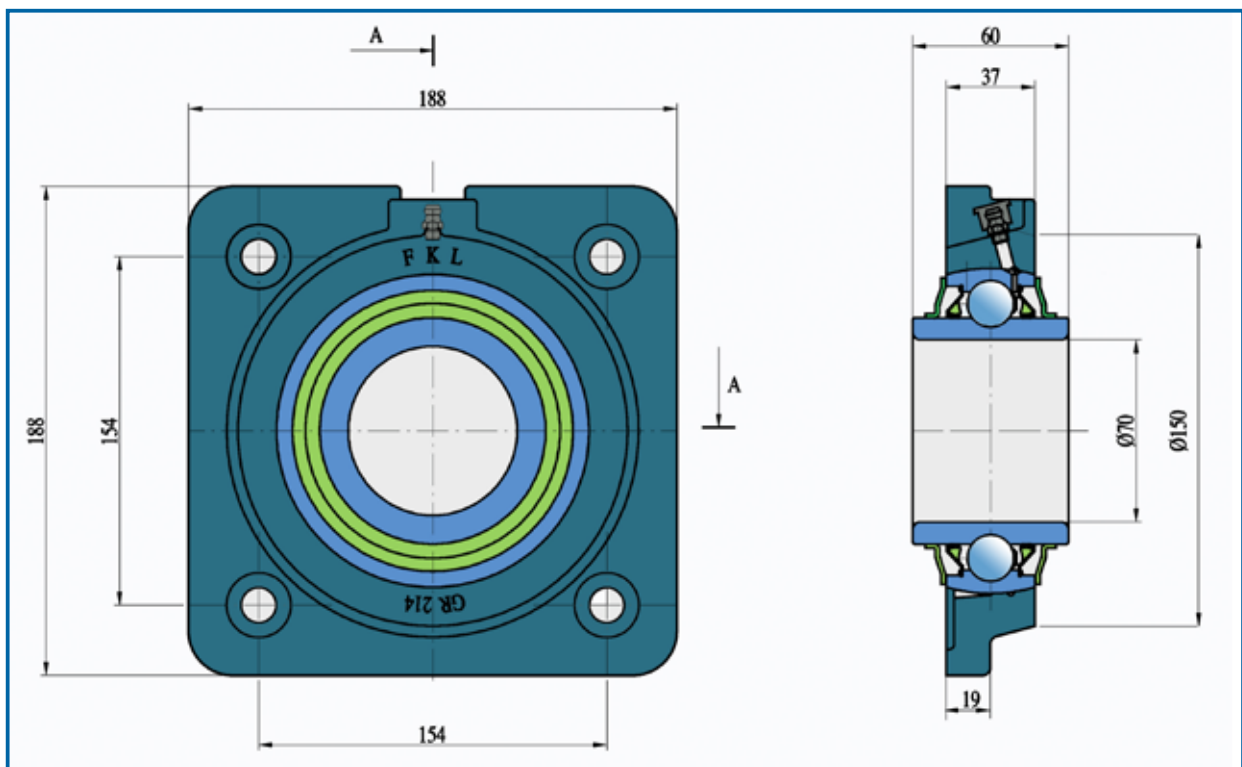

Fig. 16. LSGR 214 2TB

3.12. Bearing Units Type 2TC and 2PC

FKL has developed another series of bearing units for agriculture named LEF 2xx 2TC and 2PC.

Bearing units for disc harrows, rollers and similar reduced tillage machines, where the grass is present in excessive amounts and high probability for the machine to encounter problems with leftover ropes or winded wires on rotating shaft which tend to destroy the sealing (and a whole bearing) are developed using tin caps protection (C designation in suffix).

3.12.1. Bearing Units Type 2TC

Triple-lip seals (2T)

Instead of one-lip seals triple-lip seals are installed and this solution has been implemented for number of years. Seal has a steel reinforcement which is further zinc galvanized so it has good anti corrosion protection. Strong triple lips are made of NBR rubber resistant to lubricants and fuels. Between the lips there are 3 compartments for grease storage, which retain impurities, this preventing the penetration of dirt to the balls. More detailed info about 2T sealing see on page 10.

Cap

As additional protection from rough dirt (grass, wire, soil, mud,...) and mechanical impact of foreign matter e.g. rubble, protective sheet of the series 2TB, has been replaced with an increased thickness steel cap (1,5-2 mm), that covers the whole front of the bearing unit. Increased thickness and surface protection improves longer operation life. The tin is mounted below the cast housing tightening screw. It also has protective function for the triple and five-lips seal, because it is mounted in front of the seal and prevents penetration of rough dirt to the seal and protects it from mechanical impact.

Lubrication

These series are enabled for additional lubrication by means of lubricators.

Cone countersinks are made at angle of 120° , one per side. This results in a better flow and entry of grease which makes easier to bring grease in the contact zone of balls and raceways.

Grease flow is better due to the increased diameter of the intake grease hole and number of holes is increased from 2 to 3.

Housing material

Material selected for 2TC housings is Gray Cast Iron EN-GJL-200 but also can be ductile iron EN-GJS-500-7 which has many advantages comparing to Gray Cast Iron in terms of the strength of structure, resistance to shocks, vibrations, abrasion and therefore longer life span. Color of these housings can be standard factory blue or black.

3.12.2. Bearing Units Type 2PC

Bearing units named LEF 2xx 2PC have the same performance as bearing units LEF 2xx 2TC with only difference regarding the sealing. Instead of triple-lip seal this unit has five-lip seal.

Five-lip seal (2P)

Instead triple-lips seals, they are incorporated with newly developed seal, five-lip seal. Seal has a steel reinforcement which is zinc galvanized and has good corrosion protection. Five strong lips are made out of new type NBR rubber, resistant to oils and fuels, and resistant to high temperatures above 110°C . More detailed info about 2P sealing see on page 10.

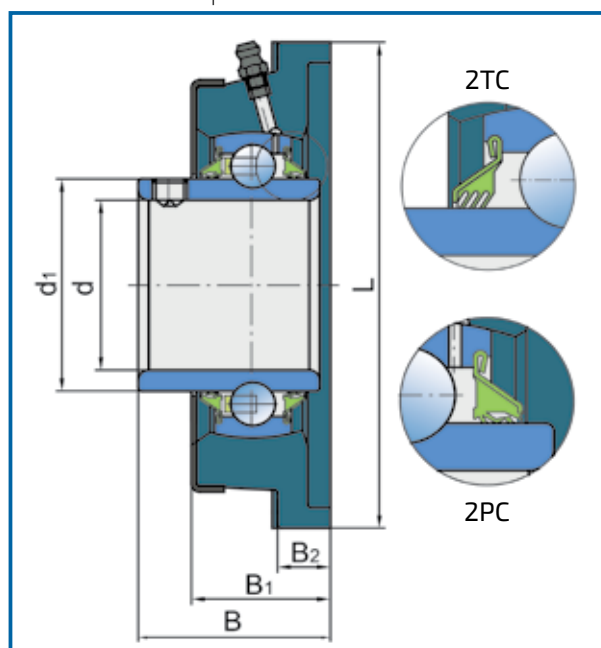

Fig.17. Bearing units type 2TC and 2PC

ARMOR LEFG...TDT Bearing Unit **REVOLUTIONARY SOLUTION**

This presents today the best sealing system for application in agricultural machinery!



Standard FKL Bearing Unit

Housing Improvements

- Housing is made of Ductile Cast Iron,
- Tensile strength is two and half times higher than housing made of standard Grey Cast Iron,
- Zinc-coated housing, Iron Arc and inner ring of the bearing reliably protect against corrosion,
- New Armor maintenance free bearing unit contains high grade lithium-based grease good for use over a long period, which is ideally suited to sealed type bearings,
- There is no need for any relubrication facilities it saves money and time,
- The sealing design eliminates the possibility of grease leakage.

Developed so Far

Armor bearing units in sizes 206, 207, 208, 209, 210, 212, 214.

Designation	Material	Tension of liquid (MPa)	Tensile strenght (MPa)	Elongation (%)
EN-GJL-200	Grey Iron	130	200	0,5
EN-GJS-500-7	Ductile Iron	320	500	7

Conclusion: Durability of housings/units made from Ductile Iron is double then durability of housings/units made from Grey Iron.

* Other types of Y bearing units are possible in Ductile Cast Iron.

3.14. Suffixes and Prefixes

Suffixes Sealing Types

ZZ	Metal shield (non contact sealing) on both sides
2RS	One lip rubber metal seal on both sides
2RS1	One lip rubber metal seal on both sides
2L	The cover + protector (on both sides)
2S	One lip rubber metal seal (on both sides)
2F	One lip rubber metal seal + f linger, on both sides
2T	Three lip seal on both sides
T	Outer ring: with a fixing nail inside the housing
2B	Rubber-metal seal+lup flinger, on both sides
2TC	Three lip seal on both sides+ metal cover
2TB	Three lip seal + metal shield, on both sides
TDT	Three lip seal at one side, double three lip seal on other side
FS	Sealing with one lip seal and a protective metal ring at one side and one lip seal on the another side
TBS	Sealing with three lip seal and a protective metal ring at one side and one lip seal on the another side
TBT	Sealing with three lip seal and a protective metal ring at one side and three lip seal on the another side
2P	Five lip seal on both sides
2PB	Five lip seal and metal shield, on both sides
2PC	Five lip seal on both sides + metal cover
P	Triple lip seal on one side, cylindrical surface of outer ring
PP	Triple lip seal, cylindrical surface of outer ring
PB	Triple lip seal on one side, spherical surface of outer ring
PPB	Triple lip seal, spherical surface of outer ring
RR	One lip seal cylindrical surface of outer ring
RRB	One lip seal spherical surface of outer ring
KPP	Triple lip seal cylindrical surface of outer ring
KPPB	Triple lip seal spherical surface of outer ring
KR	One lip seal on one side, cylindrical surface of outer ring
KRR	One lip seal, cylindrical surface of outer ring
KRB	One lip seal on one side, spherical surface
KRRB	One lip seal, spherical surface
KRP	One lip seal on one side and on the other side is triple lip seal

Y Program - Outer Ring Types

A	Bore for lubrication opposite of lubrication
H	No lubrication hole
S	Cylindrical outer ring
SN	With a groove for circlip
SNR	With a circlip

Special Surface Protection

Zn	Galvanized: Zn1, Zn2, Zn6, Zn8, Zn9, Zn28,...
Br	Bromed: Br1, Br2, Br6, Br8, Br9, Br28,...
	1-... outer ring
	2-... inner ring
	6-... flinger
	8-... locking collar
	9-... all outside surfaces
	28-... inner ring + locking collar

Y Program - Special Design

S0	For temperatures above normal (150°C)
----	---------------------------------------

Y Program - Type of Inner Ring Tightening

U	Version without eccentric ring
E	Tightening with locking screws
Y	Tightening with excenter rings
S	Compact fit tightening
K	Conrad, non filling slot type
D	Tightening with excenter ring of low profile
C	Old type of ring tightening
X	Inner ring modification: X, X1, X2,...
Y	Outer ring modification: Y, Y1, Y2,...

Suffixes Sealing Types

N	Snap ring groove in outer ring
NR	Snap ring groove in outer ring with snap ring
SH	Cylindrical outer ring without lubrication holes
L	Left thread
R	Right thread
C2	Radial internal clearance less than Normal
C3	Radial internal clearance greater than Normal
Q	Optimized contact geometry and surface finish
B	Spherical outside diameter
B.2RS1	One lip rubber metal seal on both sides and contact angle 25°

Prefixes

FN	F hosing from Ductile Cast Iron
NN	N hosing from Ductile Cast Iron
SN	S hosing from Ductile Cast Iron
GR	Housings from Ductile Cast Iron
NR	Housings from Ductile Cast Iron
HG	Housings from Ductile Cast Iron
HGR	Housings from Ductile Cast Iron
GW	With lubrication groove, wide ring single row
W	Permanently lubricated, wide ring single row
VP	Bearing with shaft
IL	Old version of Agro Point with longer body
IL2	Agro Point disc harrow hub
PL	Hub with bearing
LR	Pulley
SL	Special ball bearing
SLE	Special ball bearing
SLU	Special ball bearing
D	Special ball bearing
SLO	Special ball bearing
SLK	Special ball bearing
SP	Special ball bearing
SPR	Special ball bearing
TRB	Special cylindrical bearing

• Cardan Shafts

Cardan Shafts for Agriculture, Industry, Motor Vehicles and Parts of Cardans



• Other Type of Bearings

Cylindrical Roller Bearings
Spherical Roller Bearings
Needle Roller Bearings
Clutch Bearings
Ball Bearings for Automotive Industry



• Special Type of Bearings

Bearings Made According to Customers Demand



• Housings

From Gray Cast Iron and Sheet Metal



FKL

• Ball Bearings



• Agricultural Program

Disc Harrow Machines
Seeding Machines
Packer Rollers
Combines
Universal Solutions

• Bearing Units

5. FKL Distributors

AC AGROCENTAR DOO, Slovenia
www.agrocenter-sempeter.eu

AGRIPARTNER, France
www.agripartner.fr

AGRO-ROLL 96 KFT, Hungary
www.agroroll.hu

AGRO AUTO, Montenegro
www.agro-auto.com

AUCKLAND BEARING DISTRIBUTORS LTD,
New Zealand www.aucklandbearings.co.nz

BEARING WAREHOUSE LTD, UK/Ireland
www.bearingwarehouse.co.uk

CELSAN ITALIA S.R.L., Italy

COMPENSA, Austria
www.compesa.at

EKOAL, Bulgaria
www.ekoalbg.com

EL MASRIA FOR TRADING, Egypt/Saudi Arabia
www.elmasria.org

FKL RUS LLC, Russia
www.rusfkl.ru

FKL BY, Belorussia
www.fkl.by

FKL CZECH s.r.o., Czech Republic/Slovakia
www.fkl-czech.cz

FKL PARS, Iran

FKL POLSKA sp.z.o.o.sp.k., Poland/Baltic States
www.fkl-polska.pl

FKL ROMANIA SRL, Romania/Moldova
www.greenland.com.ro

FKL UKRAINE LLC, Ukraine
www.fkl.ua

GORIMPEX, Montenegro

HAGOP GIRAGOS, Syria

HARALD LEITZ INDUSTRIEBEDARF, Germany
www.lietz-industriebedarf.de

IWAH, Benelux Countries
www.iwahbearings.com

JOSMAR, Spain/Portugal
www.rodamientosjosmar.com

KOUIMTZIS SA, Greece
www.kouimtzis.gr

PODSHIPNIK-2007 LLC, Kazakhstan
www.fkl.kz

POINTS DIRECT PTY LTD, Australia
www.pointsdirect.com.au

PORIN LAAKERI OY, Finland
www.nomogroup.fi

S.A. AGRIEST, France
www.agriest.com

SE-KRA DOO, Croatia
www.se-kra.hr

SISA OTOMOTIV DIS TICARET LTD, Iraq

TEMKO DOO, Macedonia

TIVI GROUP LTD, Bulgaria
www.tivigroup.com

UNLU TEKNİK, Turkey
www.unluteknik.com

VULIN DOO, Bosnia and Herzegovina

AGROMARKET DOO, Serbia
www.agromarket021.com

JUSEL DOO, Serbia
www.jusel.com

LAGERTON DOO, Serbia
www.lagerton.com

MAKROM DOO, Serbia

METRO DOO, Serbia
www.metro-doo.com

NEPTUN DOO, Serbia

SET TRADE N&N DOO, Serbia

TENEJ DOO, Serbia
www.tenej.com

CATALOGUE

Edition
2018/1

Copyright © 2018/1 FKL. All rights reserved.

These contents are the copyright of the publisher and may not be reproduced, in total or partially, without express consent of the publisher. Every precautions were taken to ensure the accuracy of the information in this publication but no liability can be accepted for any errors or omissions. Prepared in Factory of rolling bearings and cardan shafts Temerin, Serbia

Editor in Chief: Laslo Koman, *B. Sc. Mechanical Enginner*

Copy Editor: Zoran Jandrić, *B. Sc. Mechanical Enginner*; Biljana Obrenović, *Master in Mechanical Engineer*

Photos, Layout and Prepress: Jasenka Martinović and Monja Madić, *Master in Graphic Engineer and Design*



Factory of Rolling Bearings and Cardan Shafts

Industrijska zona bb
21235 Temerin
SERBIA

Head of Sales +381 21 6841 222
Foreign Markets +381 21 6841 190
+381 21 6841 205
+381 21 6841 201
+381 21 6841 187

www.fkl-serbia.com

sales@fkl-serbia.com

marketing@fkl-serbia.com

Edition
2018/1